

A CONCEPT FOR THE USE AND INTEGRATION OF SUPER- CONDUCTING MAGNETS IN STRUCTURAL SYSTEMS IN GENERAL AND MAGLEV GUIDEWAY MEGA-STRUCTURES IN PARTICULAR

BY: Wilfred T. Ussery

In Association With:

**Drs. Eric and Johnetta MacCalla, Dr. Mahjoub Elnimeiri, Myron Goldsmith
Sharon Madison Polk, Mozella Jenkins, Dr. Robert H. Bragg**

I N T R O D U C T I O N

Recent breakthroughs in several different fields now make it possible to incorporate the use of superconducting magnets in structures in ways which enhance the performance of structural members or components of structural systems in general and Maglev guideway mega-structures in particular. The building of structural systems which connect appropriately scaled superconducting magnets with the post-tensioned tensile components of beams, girders, or columns would, if coupled with 'state of the art' structure monitoring, feedback and control systems, and advanced computer software, constitute a distinct new generation of structures that would possess the unique characteristic of being heuristic and demand or live-load responsive. The holistic integration of powerful superconducting magnets in structures so that they do actual structural work, creates a class of 'technologically endowed' structures that, in part - literally substitute superconductive electric power and magnetism for concrete and steel. The research and development engineering, and architectural design issues associated with such a 'technologically endowed' structural system can now be conceptualized, designed, computer simulated, built and tested.

The Maglev guideway mega-structure delineated herein incorporates these concepts, and is designed for operation in the median strip of U.S. Interstate Highway 5 from San Diego to Seattle and Vancouver, and possibly on to Fairbanks, Alaska. This system also fits in the median strip of U.S. Interstate Highway 55 and 95 North-South, and 80 and 10, East-West. As a Western Region "Peace Dividend" project, it could become a National or Bi-National research, design and build, super turnkey project that would create thousands of jobs by applying superconducting, material science, electronic, aerospace and other defense industry technologies to a multi-vehicle, multi-use Maglev guideway mega-structure that integrates urban mass transit Lower Speed (0-100 mph), High Speed (100-200 mph), Super Speed (200-400 mph), and Hypersonic evacuated tube (400-10,000 mph) Maglev systems.

G E N E R A L C O N C E P T

Recent breakthroughs in the fields of low and high temperature superconductivity make the idea of incorporating superconducting magnets in the foundations, columns, beams, and girders of some structural systems both conceptually and technologically viable. The theoretical underpinning of the idea of using superconducting magnets to enhance the performance of structural members or components is closely related to progress being made in understanding the physics of superconductivity and magnetism, the production of superconducting wires and cables that can superconductively transmit large amounts of electric current, the design of superconducting magnets, and the concurrent development of small Superconducting Magnetic Energy Storage (SMES) devices and/or flywheel motor/ generators.

The rapid progress being made in the field of super-conductivity is complimented by parallel advancement in the development and use of super computers; computer network systems; fuzzy logic

computer software enhancements; neural-like network designs; lightwave-based data transmission and memory systems; electronic and laser-based diagnostic structure monitoring, feedback and control systems; Computer Aided Design (CAD) and Computer Aided Manufacturing (CAM); and the potential use of magnetically inert non-ferrous composite materials and structural polymers in structural systems. Given the 'state of the art' of such innovative systems and technological developments, it is now possible to 'technologically endow' some structural systems with a systemically integrated set of components which combine and synergize the primary attributes of the ten different compatible areas of interest enumerated above. The related research and development, engineering, and architectural design issues associated with such 'technologically endowed' structural systems can now be conceptualized, designed, computer simulated, built and tested. This potentially historic, unachieved, structural characteristic of 'technologically endowed' structures is attributable to the synthesis of the special attributes of the following seven disparate, heretofore, unrelated principles or areas of technological achievement:

- The electrodynamic relationship of "ampere turn" or "the amount of magnetomotive force produced by an electric current flowing around one turn of a wire coil" to varying amounts of superconductive electric current. This phenomenon, with proper controls, can become demand or live load responsive to do actual structural work by the use of magnets whose power is a function of the number of windings and the amount of superconductive electric current flow around the magnet;
- The electrodynamic relationship of the direction of electric current flow through the windings around a magnet to changes in polarity of the magnets. This phenomenon with proper electronic controls can be used to engage or disengage sets of appropriately scaled shear pins in precast structural components and some architectural window wall systems.
- The ability to arrange magnets in linear, circular or spiral patterns so that the polarity of adjacent magnets is aligned to produce both repulsive and attractive 'magnetomotive force,' that simultaneously create push and pull forces that can be converted to 'mechanical force,' which acts in a common direction along a common axis. This phenomenon with proper engineering can be used to aggregate the 'magnetomotive force' of smaller magnets attached, alternatively, to the surrounding structure and directly, along the full length of tensile components of structural members.
- The electrodynamic relationship of attractive and repulsive 'magnetomotive force' produced by magnets that can be arranged, radially and spatially relative to an appropriately scaled source of repulsive 'magnetomotive force,' in a variety of geometrically stable patterns. This phenomenon with proper electronic controls, calibration of the number of windings and amount of superconductive electric current flow to each concentric array of magnets, and, the addition, in some cases, of rotation sufficient to impart appropriate amounts of centrifugal force, can be used to design and build a class of small micro-electronic devices, and a unique class of large scale, light weight, parabolic thin film structures in space.
- The currently accepted theory of elasticity: Hooke's Law, which states that the amount an elastic body bends or stretches out of shape (strain), is in direct proportion to the force (stress) acting on it. This law applies as long as the body is still elastic and has not been stressed beyond this elastic limit which will result in permanent change in the shape of the body;
- The history of research and engineering effort to optimize utilization of the tensile strength attributes of iron and steel as well as some magnetically inert non-ferrous composite materials and structural polymers -- and the compressive strength attributes of concrete in structural systems; and
- The availability of super computers, parallel processors, computer hardware networks, and the related software technology capable of providing a "distributed real-time, self-monitoring adaptive control system" to govern a heuristic, demand or live-load responsive flow of superconductive electric power to sets of superconducting magnets incorporated in a particular structural member, component, or system.

One of the most significant new opportunities for utilizing the special attributes and characteristics of a 'technologically endowed' structural system is to address the recurring guideway alignment and dynamic behavior problems associated with the movement of one or more high speed, super speed, or hypersonic evacuated tube Maglev vehicles on an elevated guideway.

The arrival and departure of a contact-free, magnetically levitated, vehicle (Maglev) at a particular structural bay of an Intra-Continental, multi-use Maglev guideway mega-structure is a predictable event. Appropriate diagnostic instrumentation and telemetry systems are now available which could ascertain and report guideway alignment and the Maglev vehicle's speed and weight prior to, and, as it moves through a particular structural bay. This would provide engineers the necessary information base to design the primary structural members or components of a Maglev guideway mega-structure not only for dead load and seismic forces, but also offer the unique, possibly historic possibility of having the structure respond heuristically and in a demand responsive way to the live load and other dynamic forces induced by the vehicles movement and presence in the bay.

One of the most important objectives to be achieved by a heuristic live-load responsive, guideway mega-structure would be the reduction or elimination of any live load induced deflection of primary structural members or components that would either incite undesirable periodicity problems or be reflected or transposed into a discernable heaving up-down motion of the Maglev vehicle as it moves at high or super speed through a low point of a longitudinal beams deflection in a particular structural bay. Superconducting magnets can be incorporated and used in structural members or components in ways that provide a solution of this special, recurring, condition - whose magnitude is in direct proportion to the length of the column bay.

The live load induced deflections or periodicity episodes initiated by the arrival and departure of one of more Maglev vehicles at a particular structural bay can now be reduced or eliminated by the incorporation and use of superconducting magnets in configurations which allow them to enhance the performance of structural members or components of Maglev guideway mega-structures. A structure with these attributes and characteristics is similar in principle to a room whose lights or mechanical systems are electronically controlled to go on and off when someone enters or leaves the room.

This can be achieved by having an "engagement" fuzzy logic enhanced protocol at the front end of the electrified, magnetized segment of the guideway that propels the Maglev vehicles. Activation of the "engagement" protocol initiates a calibrated increase in superconducting electric power around a set of superconducting magnets located at the end of the beams, girders and columns which respond by increasing the tension on the post tensioned cables in the structural members in advance of the vehicle's arrival at a given structural bay. The calibration of additional tension at the ends of the post tensioned cables is scaled to eliminate any deflection of the primary structural member, guideway misalignment, dynamic behavior, or periodicity problems for the guideway mega-structure.

There would also be a "disengagement" fuzzy logic enhanced protocol at the tail end of the electrified, magnetized segment of the guideway that propels the trailing Maglev vehicle. Activation of the "disengagement" protocol initiates a calibrated increase in superconductive electric power around a set of superconducting magnets located appropriately at the end of beams, girders, and columns which respond by decreasing the tension on the post tensioned cables in the structural member that was imposed by the "engagement" protocol.

A DISTRIBUTED REAL-TIME, SELF-MONITORING, ADAPTIVE CONTROL SYSTEM

The basic components of the distributed control feedback system required to govern a heuristic, demand or live load responsive flow of superconductive electric power to sets of superconducting magnets incorporated in a particular structural member, or components of the proposed multi-level, multi-use transit guideway mega-structure must be capable of monitoring and determining on a real-time basis all of the forces, both transient and periodic, currently acting on a particular structural member or component of the structural system. See Figures 1 and 2. It must also have memory capacity adequate enough to allow it to be able to compare the effects of its effort to past efforts, real-time. Finally, it must have the ability to iteratively calculate consecutive force equations to determine the necessary counter-action to be applied.

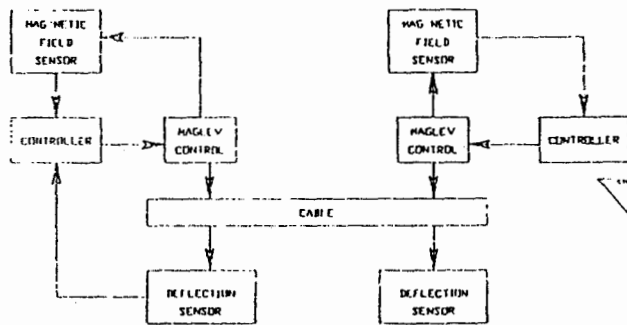

Figure 1

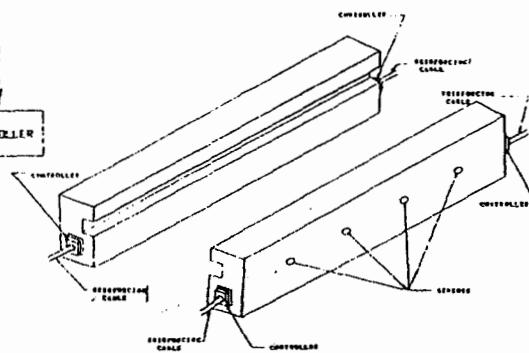

Figure 2

A very extensive set of feedback sensors is needed. These sensors must be accessible for maintenance purposes and capable of not only detecting microscopic flexing of members, but also follow the effect of the magnetically induced field on the tensile elements in the structural members and components. These sensors must be capable of collecting this data on a continuous basis. They must also be self-calibrating or capable of maintaining calibration over long time periods. There must be nearly as many sensors as there are controlled forces or the equations will be ill-conditioned and consequently not as responsive to distributive adaptive control.

The final component that is needed for the practical application of adaptive control to the use of "magnetomotive force" to "mechanical force" controlled enhancement of the performance of structural members or components of structural systems so that they become heuristic and demand or live load responsive, is a fail-safe fallback system in the event of electrical failure. If distributed adaptive control becomes an integral component of the system for enhancing the performance of structural members or components of the structural system, some method must be available for converting that effort from an active to a passive system when the real-time response is unavailable. This approach is known as graceful degradation and applied to all man missions in the aerospace arena.

Distributive adaptive control is the essence of the neural-network learning model. In it a primarily complex coupled force equation is decoupled through the use of a large quantity of independent computers each with selective feedback that is tied to the axis controlled by that computer. By operating a large quantity of these control loops in tandem, complex adaptive learning is achieved.

This approach is also applicable because of the large distances over which the system must operate. By utilizing the distributed control concept, a global problem has been essentially converted into a local problem with very tightly coupled, highly responsive feedback loops providing detailed adjustments all along the structural members. Additional models of superconductive magnets are utilized to characterize linear motion of the members. Adaptive control is applied through use of feedback sensors to estimate and predict positions and apply appropriate amounts of current to the superconducting elements. Fail safe design is utilized through use of redundancy in embedded controllers.

Sensors are used to detect position and conditions in the system. The necessary forces needed are determined through the mathematical model of the system and feedback from sensors providing feedback on the various system states. These sensors are used to determine structural integrity, temperature perturbations, stress, and physical perturbations. The guideway variations are monitored, diagnosed, and controlled through these distributed elements.

The use of distributed computing means that the non-linearity inherent in the structure are handled basically through the decoupling of independent axes. Each axis is controlled by a pair of controllers, the outputs of which are literally summed together. This is very similar to the neural-network or adaptive beam shaping approach. In fact the adaptive algorithms proposed are based on those used except we propose the digital version of those analog algorithms. Optical scanning is used as a non obstructive medium compatible with the magnetic fields generated in Maglev applications. These sensors are used to align, monitor, and control the dynamic and steady state conditions of the structural members.

Through use of distributed processors using embedded computers, appropriate modeling, distributed processing architectures, and sensor technology, the resulting system could become both economical and readily implemented through integration of presently available technology. Predictive algorithms are used and verified through an embedded communication link tying the distributed processors together over extended distances. This adds to the failsafe characteristics of the system. Power efficiency, material selection optimization, and superconductive elements are optimized through economic use of mathematical models, feedback controls, and the redundant distributed processors.

This heuristic, demand or live load responsive system, with its full array of components for a distributed control feedback system and related set of superconducting magnets also could have other modes of use for responding fully through a programmed response to any episodes of guideway alignment and dynamic behavior, foundation settling, periodicity or harmonic oscillation damping, or earthquake or wind induced motion in the multi-level, multi-use transit guideway mega-structure.

SOFTWARE FOR 'TECHNOLOGICALLY ENDOWED' STRUCTURES

When developing an appropriate monitoring, feedback, and control system, installed as an integral part of a particular structural system, numerous software related factors need to be taken into consideration. They include:

- Quality of applications produced;
- Speed of application development;
- Quality of technical support;
- Ease of use;
- Strength of programming language;
- Responsiveness of vendor service;
- Value for the dollar - cost effectiveness;
- Integration of functions within the product;
- Support for multiple server databases;
- Support for client/server communications protocols;
- Training time required to use the product;
- Quality of code generation facilities;
- Support for dividing processing tasks between client and server;
- Amount of money required; and
- Support for multiple front ends.

Consideration must also be given to Source-Routing Transparency, which supports both source-route bridging and transparent bridging. This is important to determine whether a data packet is intended for a node on the same physical ring. SRT supports both schemes in one physical box.

The comparison of protocols, interfaces, throughput, and parallel network access to relational databases can give one the increased speed needed for multiple processing. Selecting on-demand packet switched connections will facilitate being at the forefront of the newest and latest technology.

CONCEPT FOR AN INTRA-CONTINENTAL, MULTI-LEVEL, MULTI-USE MAGLEV GUIDEWAY MEGA-STRUCTURE

The multi-level, multi-use mega-structure described herein, is designed to facilitate a multi-tiered use of the median strip rights of way of the U.S. Interstate Highway System by "second or third generation" American designed and built Maglev vehicles.

The coffered foundation system and multi-level, multi-use mega-structure described herein, is also designed to accommodate the future installation of non-transit infra-structure and uses that are capable of meeting several local, regional, and national needs which are generally perceived and installed as independent systems and structures. These seemingly unrelated, separate, components of non-transit infra-structure and uses are undergoing major transformation due to recent innovations or pending breakthroughs in science and technology. These seemingly unrelated, separate, components of non-transit infra-structure and uses also enjoy an untapped, underutilized, symbiotic relationship with each other and are rendered synergistic when holistically integrated in the proposed multi-level, multi-use transit guideway mega-structure. The proposed mega-structure, more importantly, provides several unique advantages that are not attainable with a guideway system designed for single vehicle, non-consist, transit operation.

The primary modular, structural, architectural, electrical, and mechanical components for a typical structural bay of the proposed multi-level, multi-use transit guideway mega-structure include:

- A modular, precast, 1300 Cm x 1300 Cm coffered foundation system composed of four (4) subcomponents, see Figs. 3, 4, 5 and 6, that are structurally bonded by a 40 Cm wide pour strip between the subcomponents. Integral to the pour strips between the subcomponents is a 220 Cm octagonal element in the center of the foundation that is sized to accommodate the placement of a precast column over its entire length which shall extend from the bottom of the coffer to 140 Cm below the top of the foundation. See Figs. 7 and 10.
- The 20 Cm space between the inside face of the 100 Cm thick, 460 Cm wide, octagonal, precast column of the primary structural component of the transit guide-way megastructure and the octagonal 110 Cm wide x 320 Cm high element in the center of the foundation, and the space between the bottom of the precast column and the coffer shall be adjusted to accommodate an arrangement of superconducting magnets designed with sufficient power to:

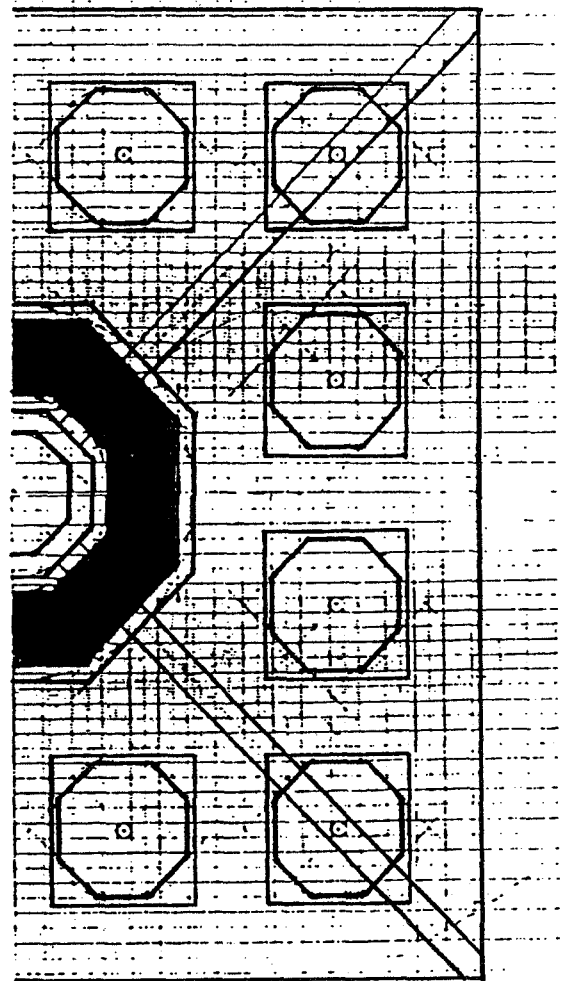

Figure 3

* Isolate the precast column of the primary structural component of the guideway mega-structure and the poured in place octagonal element in the center of the foundation, yet hold it with structural integrity in a position of proper alignment; See Figs. 6, 7 and 18.

* Isolate the precast column of the primary structural component of the transit guideway mega-structure from direct contact with the bottom of the coffer, yet hold it with structural integrity, through the use of self-aligning magnetically activated components, in a position of proper alignment. See Figs. 7, 10 and 18.

* Induce motion according to a pre-programmed fuzzy logic computer software program, to dampen, reduce or eliminate a range of periodicity problems associated with the variety of dynamic events to which the transit guideway mega-structure is subjected - including high winds and earthquakes. See Figs. 7, 10, and 18.

o The twelve (12), 200 Cm x 200 Cm x 650 Cm deep, coffer, which are produced by assembly of the four (4) modular CAD CAM, precast foundation components are configured to accommodate a specially designed, modular, CAD CAM 180 Cm wide x 400 Cm high, octagonally shaped SMES unit and/or flywheel motor/generator set whose mass is situated so that it acts integrally with the mass of the foundation itself and, which in the aggregate on a regionally scaled superspeed (200-400 MPH) or hypersonic evacuated tube Maglev vehicle system (400-10,000 MPH) offers the following possibilities: See Figs. 5, 7, 10, and 11.

* Provides a space in each foundation to build into the guideway mega-structure a modular, redundant source of superconductive electric power for each structural bay of the system.

* Provides a location for housing a network of 180 Cm octagonal SMES units capable of being a part of a program to decentralize the storage of electric power for local, regional or national electric power grid. See Figs. 4 and 7.

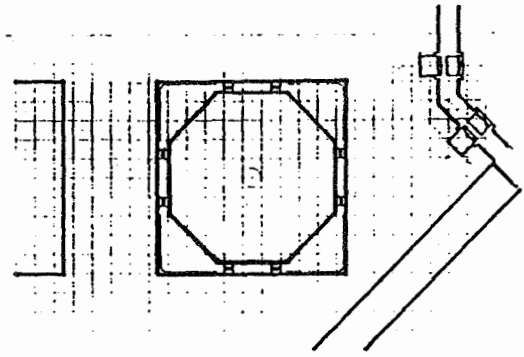

Figure 4

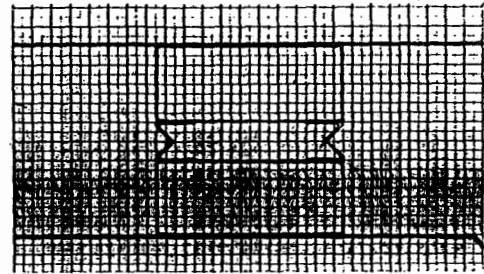

Figure 5

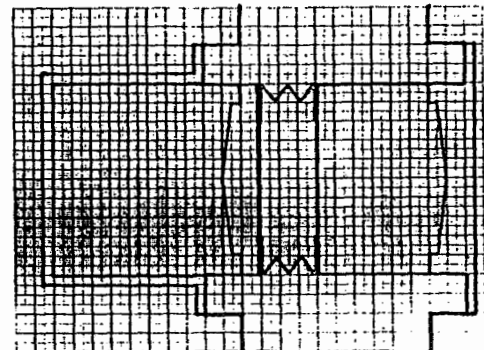

Figure 6

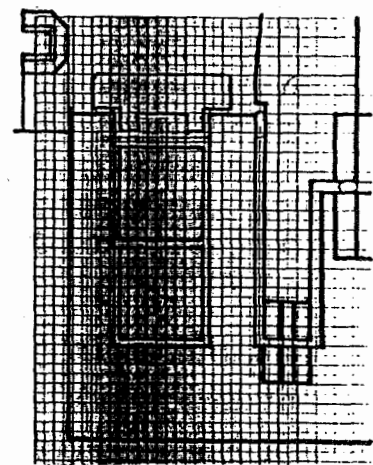

Figure 7

* Provides a triangular space at four sides of each SMES unit which shall be reserved for a series of lightwave based data transmission memory bank and capacity distance achievement functions, which if integrated with the fiber optic cables housed in the primary longitudinal girders of the guideway megastructures can, in addition to the potential of becoming an integral part of the Clinton-Gore proposed one gigabit per second, super data highway project, and also become the primary memory bank components of a regional or national information utility. This dual amenity is highly synergistic and a potential major source of non-transit revenue. This special amenity could also be made available to a broad range of potential corporate and government clients such as banks, and financial institutions, defense contractors, and local, state and federal governmental entities that would benefit from maintaining redundant, safely stored, readily accessible banks of information whose storage or redundancy was important to their organization. See Fig. 4.

- A modular, CAD CAM, octagonally shaped precast column that is designed to fit over the poured in place central octagonal element of the coffered foundation that are spaced 50 meters apart, and whose 15 meter length - above grade - is long enough to allow appropriate clearance of Interstate Highway overpass structures. See Fig. 10.
- A modular, CAD CAM, precast pair of 200 Cm wide, elongated, octagonally shaped primary structural components, designed to be secured to the top of the modular, CAD CAM, octagonally shaped precast column by superconducting magnets in attraction and a set of self aligning magnetic shear pins; See Fig. 8.
- A pair of 125 Cm wide x 200 Cm deep x 2470 Cm long rectangular, post tensioned, transverse beam components that are supported on both sides of the elongated octagonally shaped primary structural component at the mid point, bisecting it in two equal parts. The set of beams also projects beyond the outside face of the elongated, octagonally shaped primary structural components

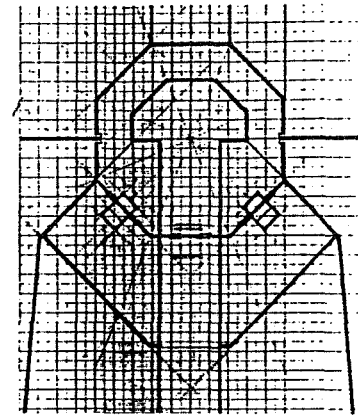

Figure 8

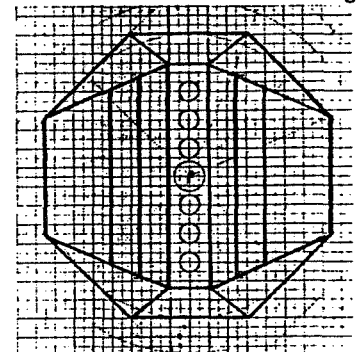

Figure 9

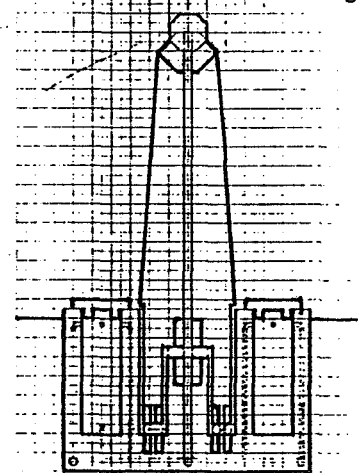

Figure 10

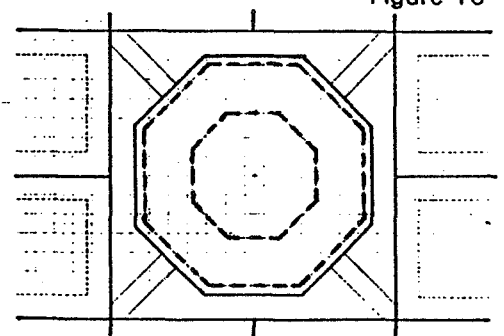

Figure 11

so that it provides support for the cambered, longitudinal, post tensioned exterior beams which are located to accommodate a 400 Cm wide superspeed Maglev vehicle on the top side of the transverse beam system and by use of the Zabar, Levi and Birenbaum air-core linear induction motor suspension and propulsion system, or use of a cylindrical Maglev system proposed by Howard Coffey of Argonne National Laboratory's Center for Transportation Research, support a 400 Cm wide intermediate to high speed Maglev system which could operate using urban stop criteria used by BART in the San Francisco Bay Area, WMATA in Washington, D.C. or Marta in Atlanta, Georgia. See Figs. 16, 18, and 19.

- The octagonal 200 Cm wide, elongated octagonally shaped primary structural component at 750 Cm wide x 1600 Cm high, inside face to inside face, is wide and high enough to accommodate, when bisected a future 4450 Cm long x 672 Cm wide-body Maglev vehicle, which after a period of 5 to 20 years of research and development, can be enclosed in solid-state electrochromatic glass for further development as an evacuated tube or vacuum, tilt-body, hypersonic Maglev system. This arrangement of transverse beams also creates a 200 Cm wide x 200 Cm deep x 750 Cm long space between the inside faces of the elongated octagonally shaped primary structural components and the transverse beams that can be used as the mechanical bay for housing a modular family of mechanical, electrical, and electronic or lightwave-based equipment designed to meet the needs of each structural bay; See Fig. 16, 18 and 19.
- A pair of cambered, 400 Cm wide x 560 Cm deep, post tensioned girders - the primary longitudinal structural components of the proposed Maglev mega-structure - that are designed to span from one elongated octagonally shaped primary structural component to the next; See Fig. 14, 18, and 19.
- A pair of cambered, 240 Cm wide x 560 Cm deep post tensioned, exterior beams, See Figs. 15 and 16, supported at the ends of the 125 Cm x 200 Cm rectangular transverse beams and whose

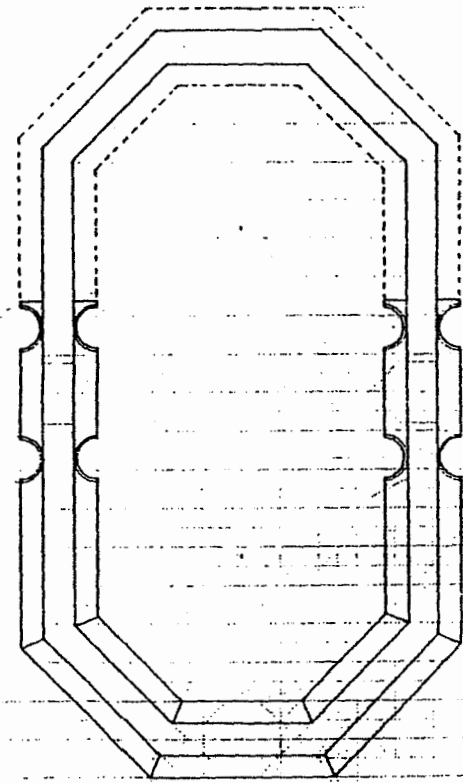

Figure 12

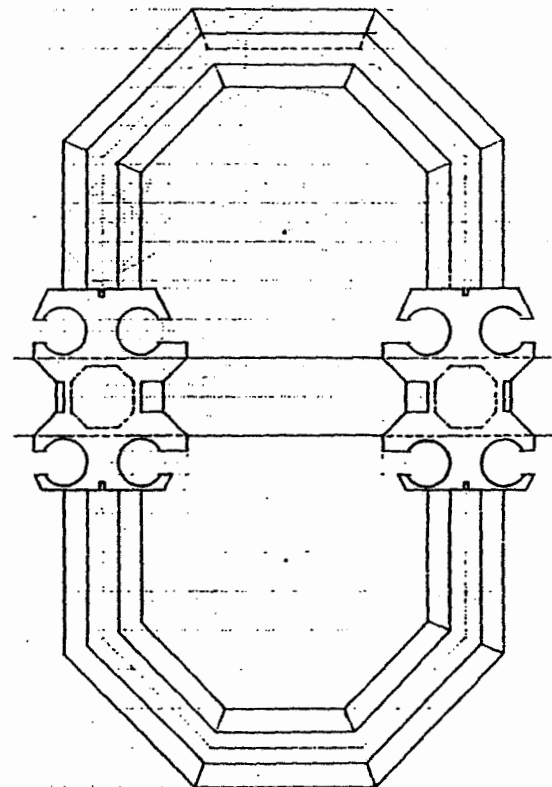

Figure 13

length, although centered on the elongated, octagonally shaped primary structural component is one third of the 50 meter span between the elongated, octagonally shaped primary structural components which in turn supports:

- * A pair of transverse, cambered post tensioned beams of similar cross section to the ones adjacent to the elongated, octagonally shaped primary structural components which in this instance are also fixed in place between the exterior beams and primary longitudinal girders with a set of magnetically activated self-aligning shear pins; See Fig. 18 and 19.

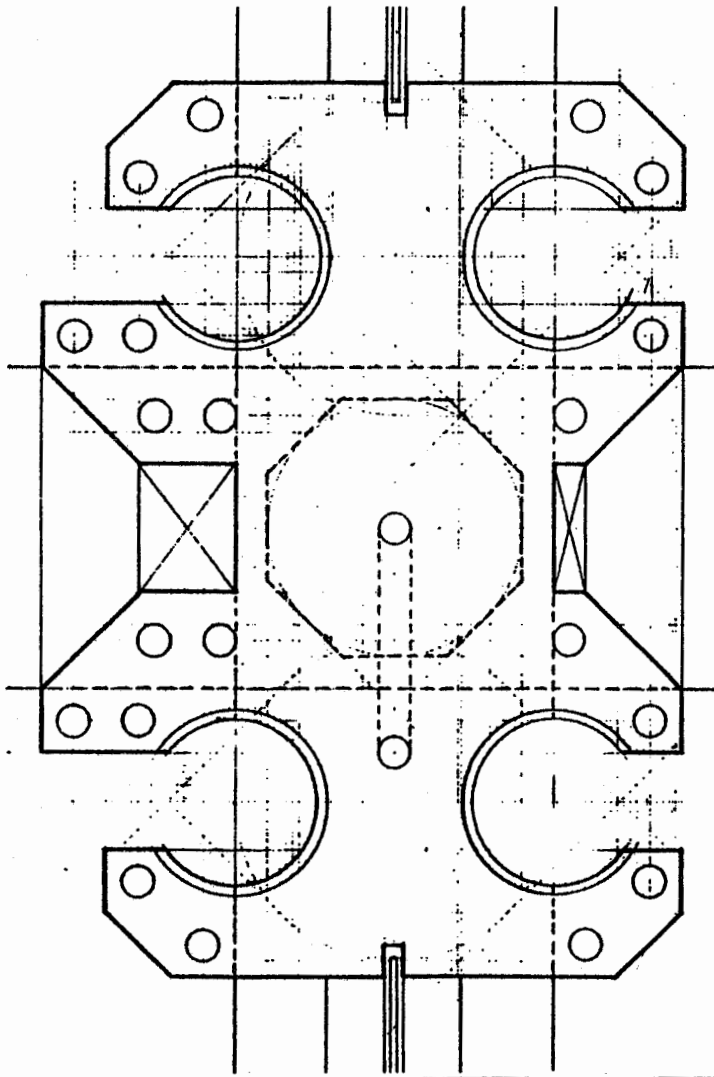

Figure 14

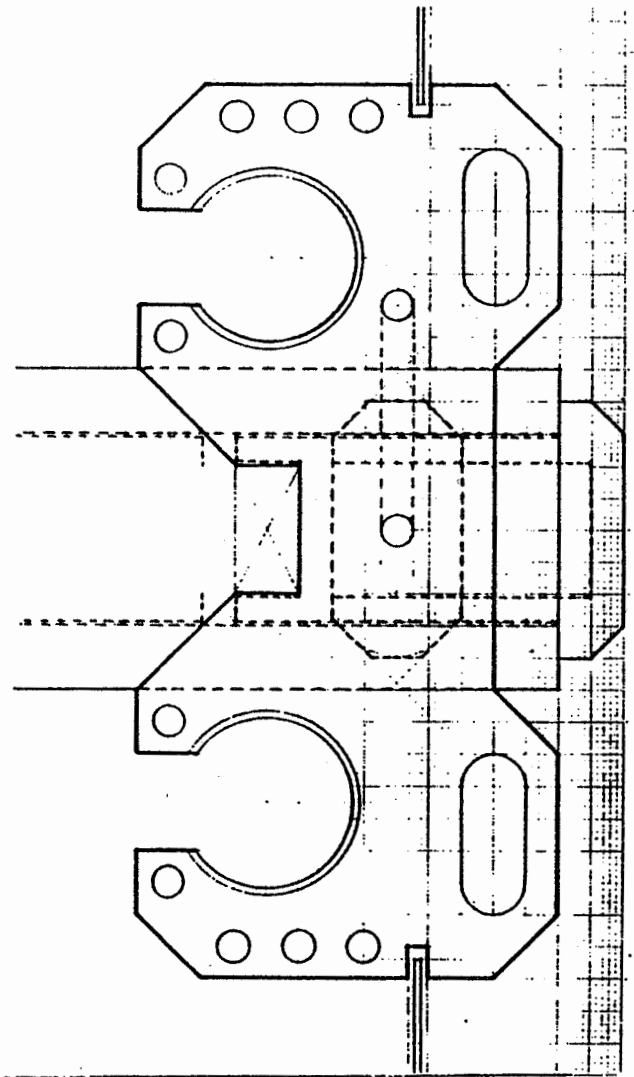

Figure 15

- o Provide a series of cavities in the flange and web of both the primary girders and exterior longitudinal beams that are capable of accommodating a variety of non-transit uses that can become significant generators of revenue of sufficient amount to offset the additional costs associated with the coffered foundation and larger multi-level, multi-use guideway mega-structure such as:
 - * Fiber optic cable space large enough to meet the needs of the proposed one gigabit per second, National Research and Education Network (NREN), and other users of fiber optic cable such as AT&T, local Bell Systems, Sprint, MCI, and the proposed High Definition Television (HDTV) ground based fiber optic network; See Fig. 14.
 - * Superconducting electric power transmission cable space, reserved for the initial increment of programs to retrofit local, regional, and the nation's electric power grid to superconducting electric power transmission lines; See Fig. 14 and 15.
 - * A vacuum tube system that could be operated by the U.S. Postal Service, United Parcel, or Federal Express, for developing a "same day" delivery service for letters and small parcels between major metropolitan centers. See Fig. 15.
 - * Dedicated space and/or external piping systems designed to accommodate the transport of deep aquafur, special spring, or Alaskan sourced high quality drinking water, petroleum products, and cryogenic liquids produced as a by-product of the maintenance of the solid-state electrochromatic glass enclosed evacuated tube or vacuum for the Hypersonic Maglev Vehicle System; and also capacity to accommodate the future exponential increase in the need to transport nitrogen and other cryogenic liquids associated with an ever-expanding low and high temperature superconductivity industry.

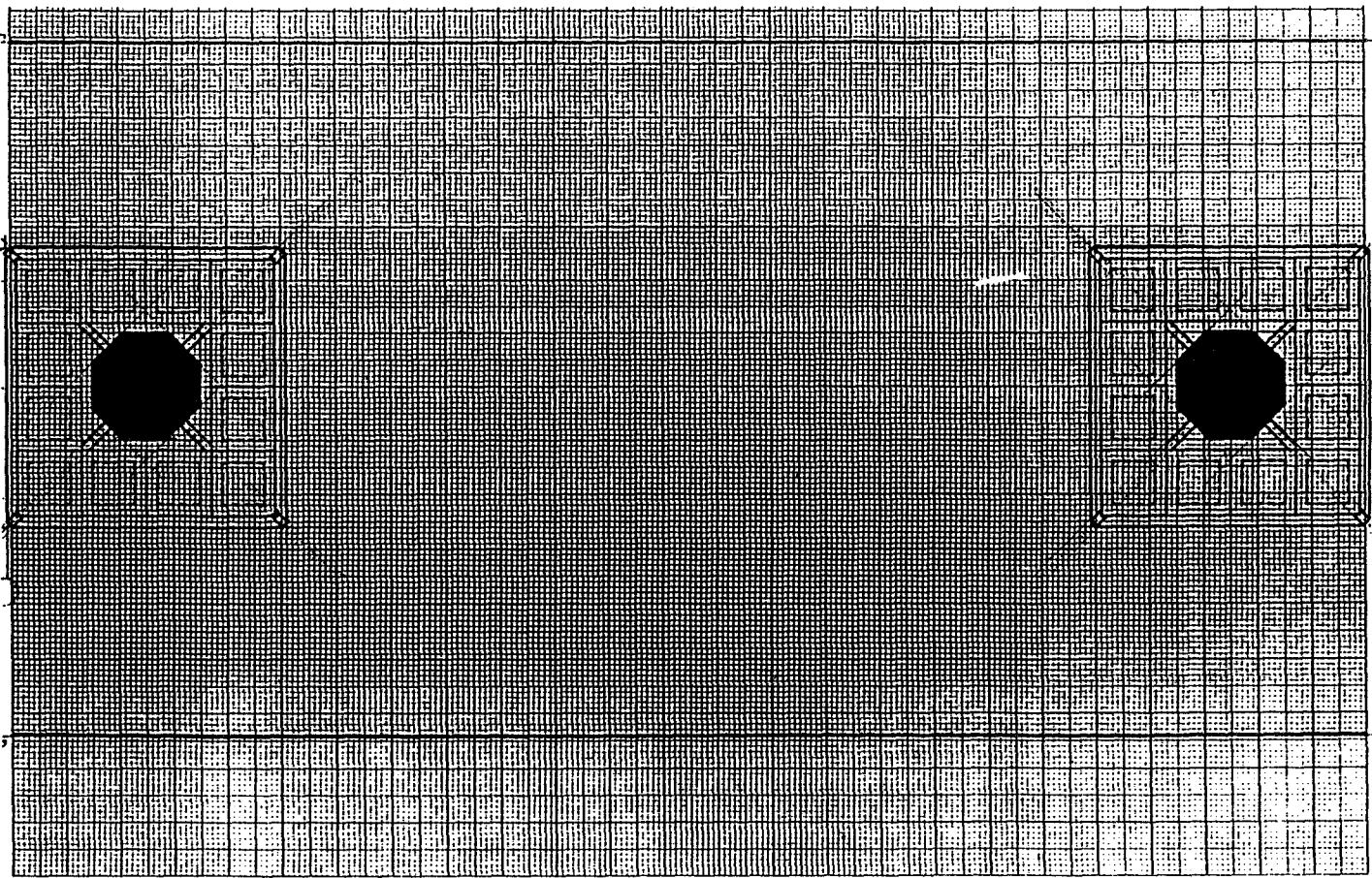

Figure 16

METHODOLOGY TO DEFINITELY EVALUATE CONCEPT OF A 'TECHNOLOGICALLY ENDOWED' STRUCTURE

The idea of a 'technologically endowed' structure is to utilize powerful superconducting magnets as generators of 'magnetomotive force' that can be converted to 'mechanical force', and when regulated and channeled properly, can be used advantageously to control the response of structures to live load induced deflections and or excitations of a particular structural member or component of a structural system. The objective is to be able to reduce or altogether eliminate any live load induced deflections and or excitations of the primary structural members. The process of control and regulation can be achieved by the utilization of a 'state of the art' distributed real-time, self-monitoring, adaptive control system - coupled with 'state of the art' micro and super computer systems. This distributed control feedback system is required to govern a heuristic, demand or live load responsive flow of superconductive electric power to the windings of sets of superconducting magnets incorporated in a particular structural member or components.

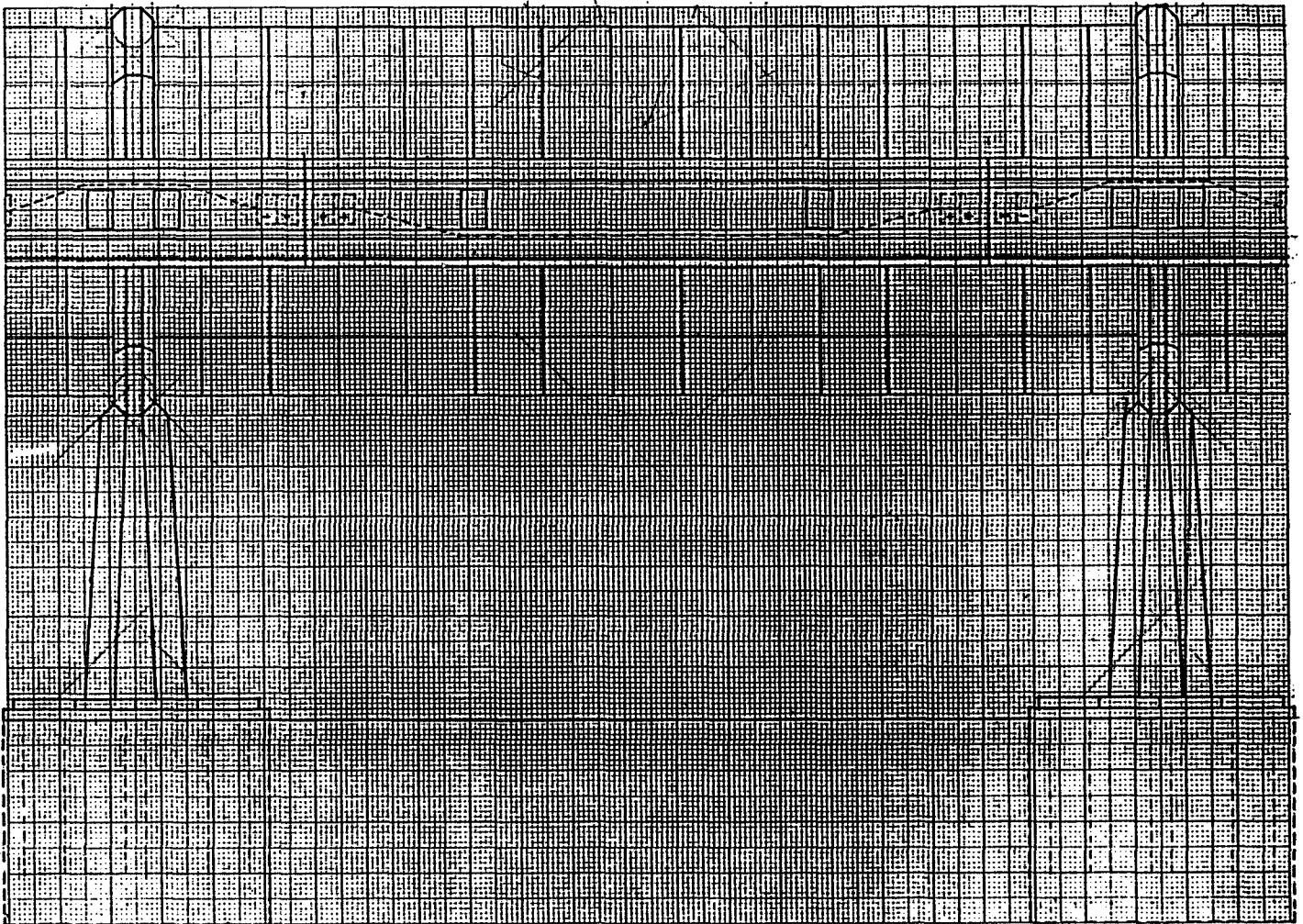

Figure 17

Because of the complexity, symbiotic relationships, and potential synergy of the proposed 'technologically endowed' structural system for the proposed multi-vehicle, multi-use Maglev guideway mega-structure, the following ten areas of research should be undertaken:

1. Study and evaluate the possibility of transferring, in structurally significant values, 'magneto-motive force' into appropriately agile 'mechanical force' and the relationship of the direction of electric current flow to polarity that will include the following experimental approach:
 - Small scale lab models;
 - Large scale (full size) models.
2. Computer simulation of live-load responsive structural members, superconductively activated structural components, and the proposed 'technologically endowed' structural system relative to geometric design, size and power of superconducting magnets needed to do actual structural work - a major numerical undertaking.
3. Surveying of 'state of the art' of available research and development of the interaction between structural materials including structural polymers and some magnetically inert non-ferrous composite materials which might be used as possible substitutes for concrete and steel.
4. Study and evaluate applicability of the 'technologically endowed' structure concept to spans longer than 50 meter spacing of the proposed structure:
 - 100 meter span
 - 250 meter span
 - 500 meter span
 - 1,000 meter span
5. Study and evaluate the applicability of 'technologically endowed' live-load responsive structural systems for use on space-based platforms or structural systems.
6. Study and evaluate utilizing 'state of the art' electronic and laser based diagnostic structure monitoring feedback and control systems in the prototype structural system.
7. Study and evaluate capabilities of the prototype structure to compatibly provide additional space for the lightwave-based data transmission and memory systems associated with the Clinton-Gore proposed one gigabit per second Super Data Highway Project.
8. Study and evaluate the feasibility and economic advantages of utilizing 'state of the art' Computer Aided Design (CAD) and Computer-Aided Manufacturing (CAM) technology for the prototype 'technologically endowed' structure.
9. Study and evaluate the feasibility of generating electric power from photo voltaic cells located in the exterior surfaces of the guideway structure and on the roof of the Maglev vehicles sufficient to service the hotel functions of the guideway and vehicle systems.
10. Study and evaluate the feasibility of locating a network of satellite receivers on the guideway structure sufficient to facilitate it becoming a linear teleport.

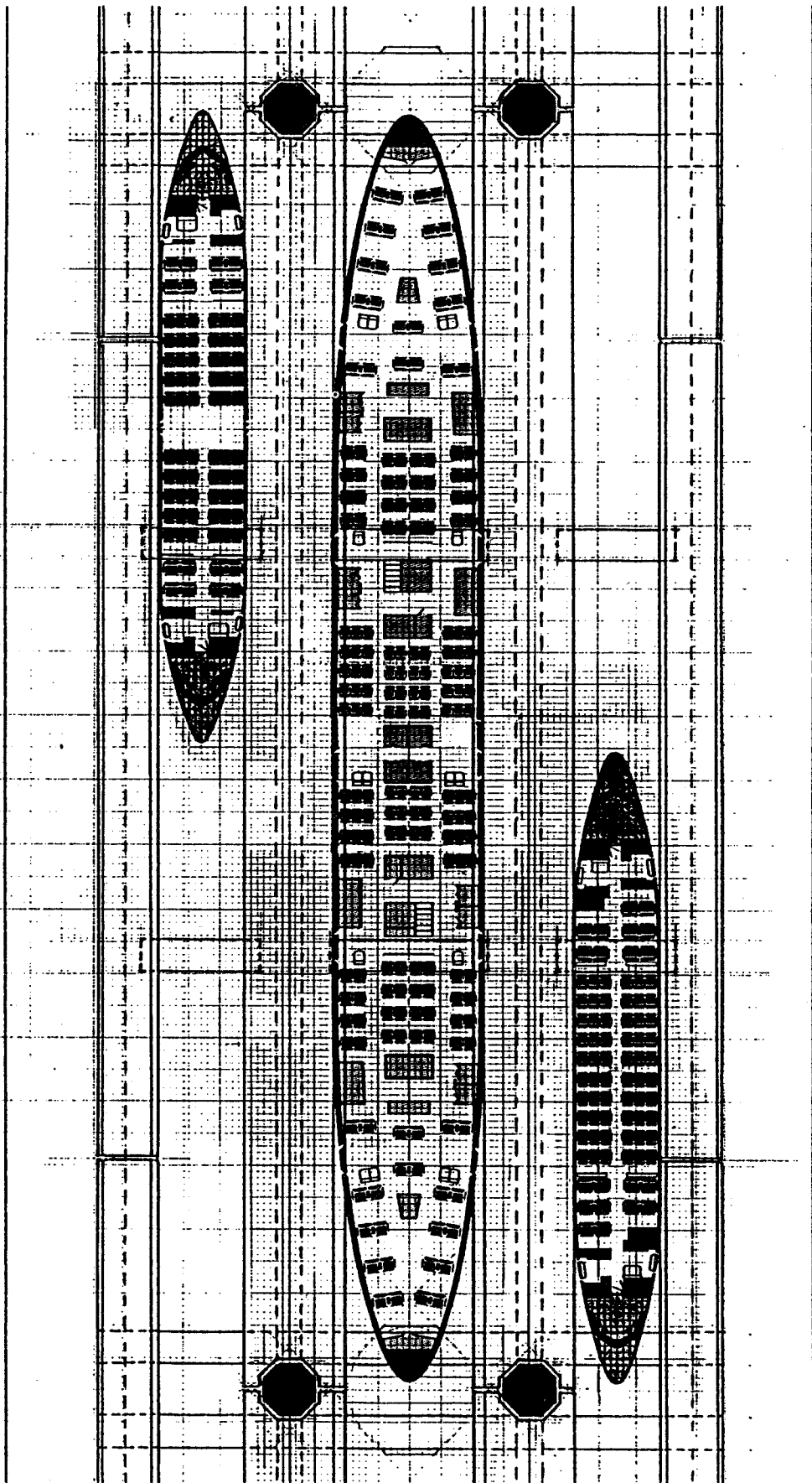
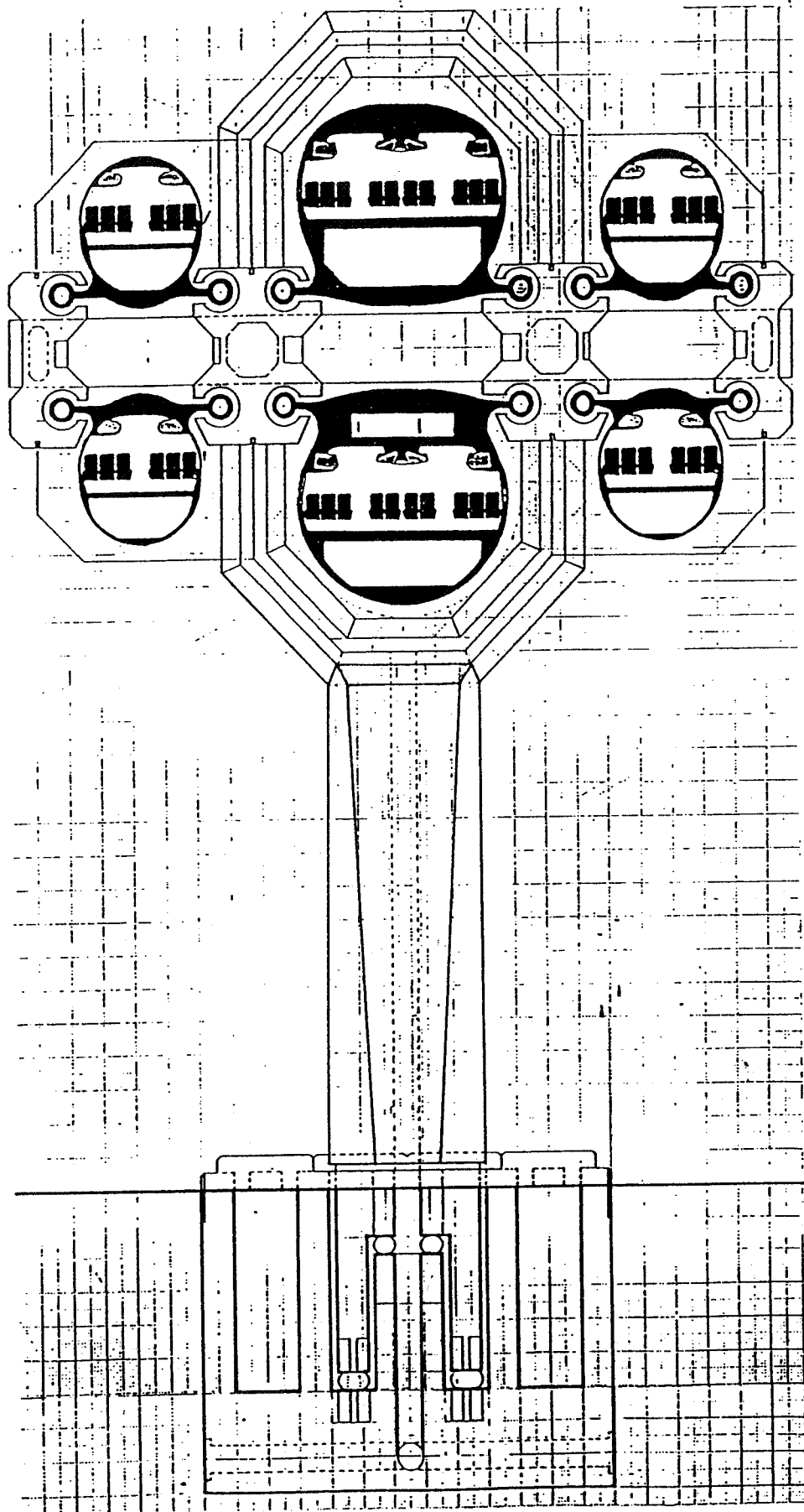
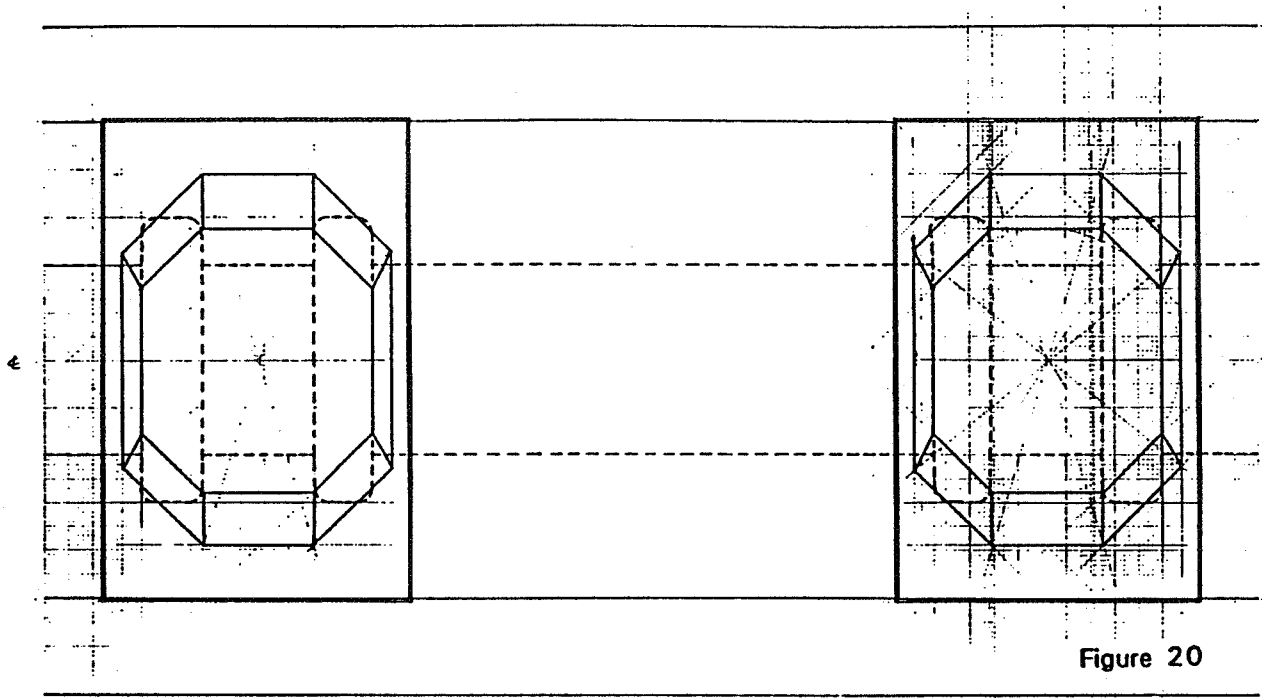

Figure 18





RECOMMENDATIONS AND CONCLUSIONS

Several recommendations regarding determining the feasibility of 'technologically endowed' structural systems are worthy of consideration. They include the following:

- A consortium of private sector and public sector members, including universities and national research laboratories, should be organized to conduct the ten point research study proposed herein, as a methodology to definitively evaluate the concept of a 'technologically endowed' structure;
- Conduct a definitive evaluation of the people moving and cargo carrying capabilities of the Maglev guideway mega-structure delineated herein, and determine whether or not a "technologically endowed" Maglev mega-structure designed to achieve multiple transit and non-transit goals would radically transform the economics of Maglev guideway systems by providing several unique income-generating capabilities that are unattainable with smaller guideway systems designed for single vehicle, non-consist, transit operation; and
- Identify the optimum North-South and East-West Interstate Highway Systems whose median strip rights of way are the natural location for multi-level, multi-vehicle, Maglev guideway mega-structures, similar in scale to the one delineated herein, which should not be pre-empted with the premature installation of bi-directional, single vehicle Maglev systems.
- Conduct an evaluation of the axiomatic relationship of mobility to military force structure and the potential to achieve a prudent reduction in U.S. military force structure as a consequence of installation of the proposed multi-vehicle, multi-use Maglev guideway megastructure in the median strip of U.S. Interstates 5, 55, and 95 North-South and 80 and 10 East-West.

The building of 'technologically endowed' structural systems constitutes the beginning of the epoch of a new generation of structures. Each new generation of 'technologically endowed' structures should improve the ability to address a broad variety of performance enhancements in structural members, components and systems, including the use of superconducting magnets in shims and self-aligning shear pins for facilitating the erection and/or disassembly of CAD/CAM precast structural systems. Over time, succeeding generations of 'technologically endowed' structural systems can be expected to achieve even greater efficiency in the art of substituting superconductive electric power and magnetism for concrete and steel.

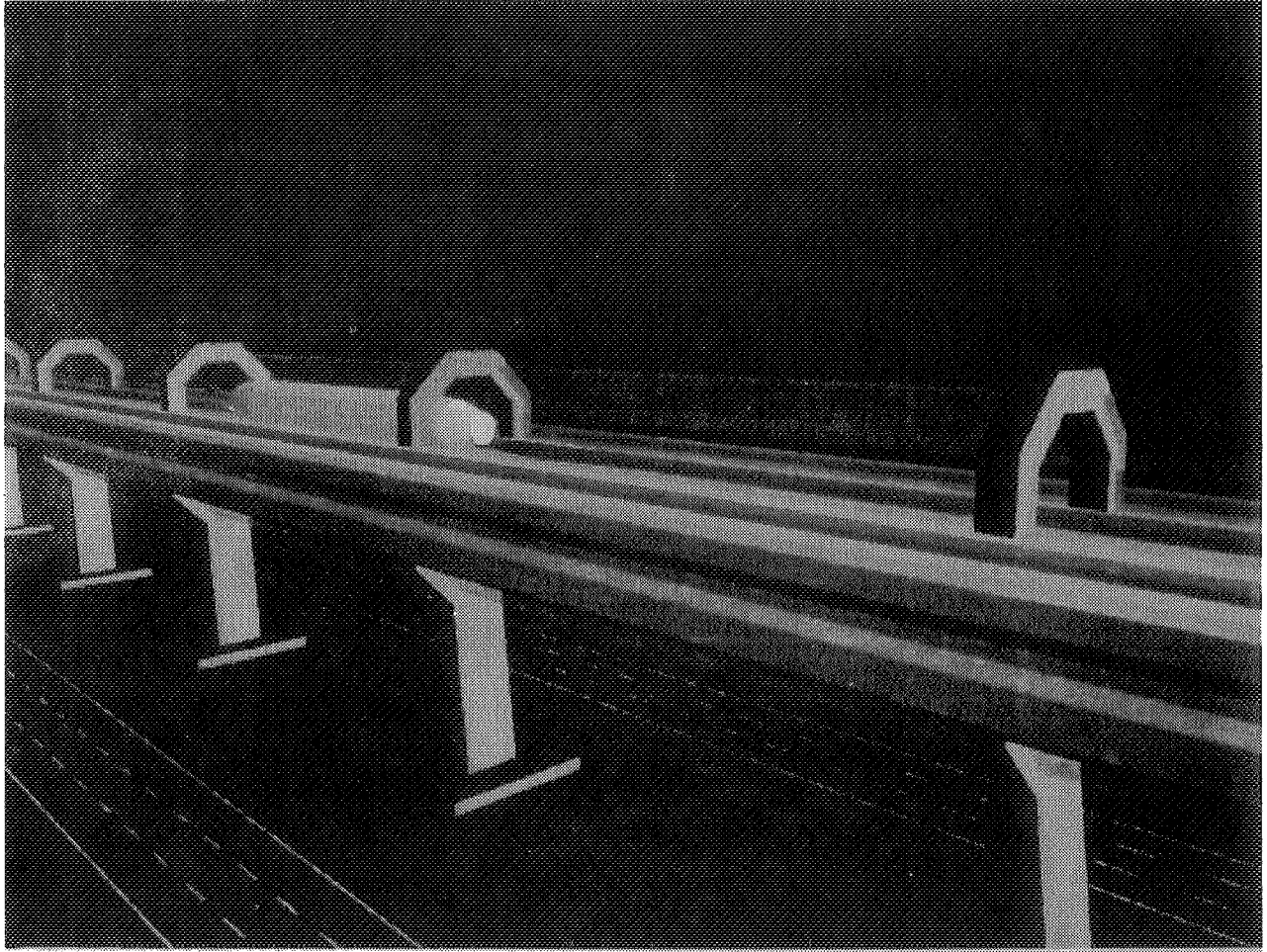

FIGURE 21

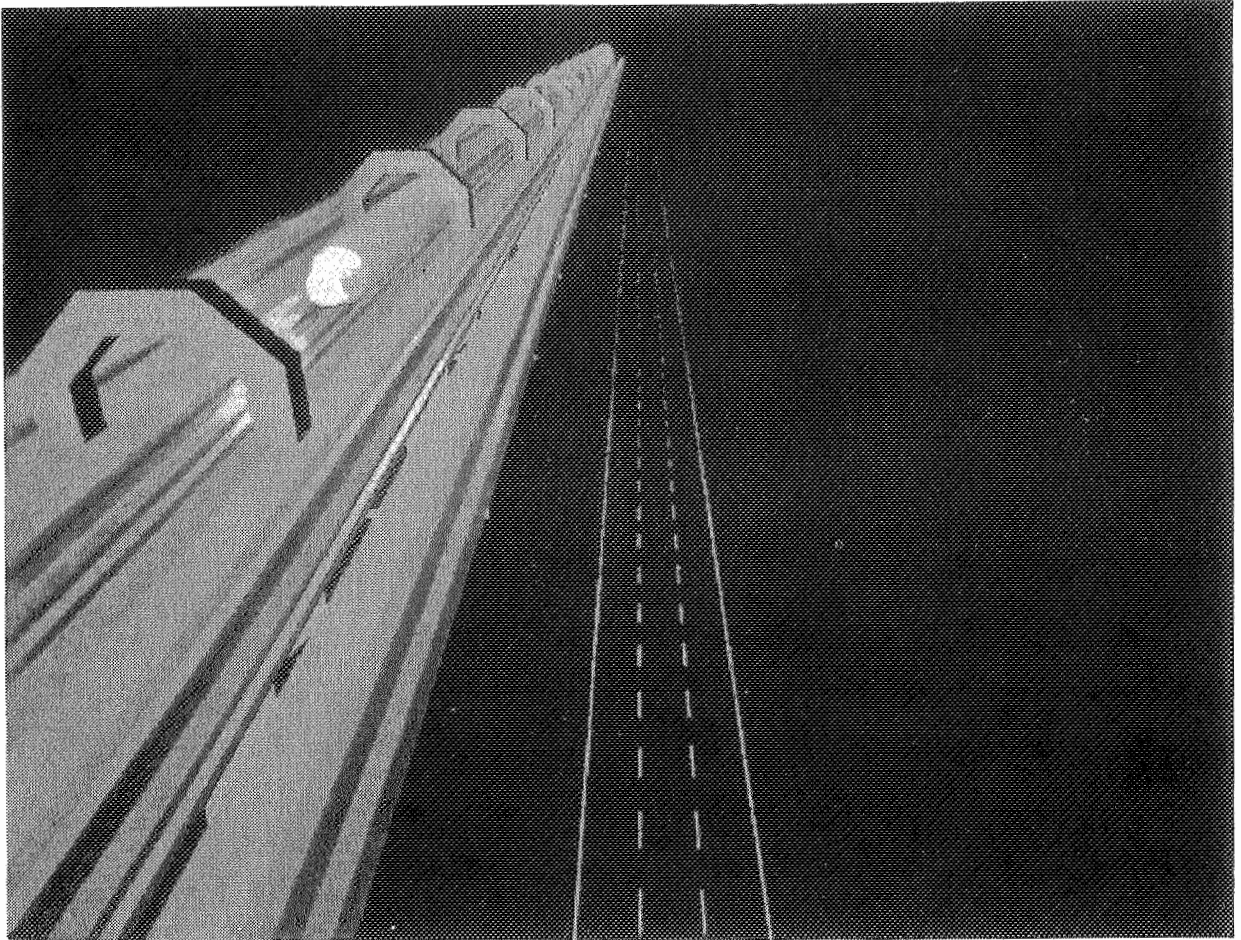

FIGURE 22

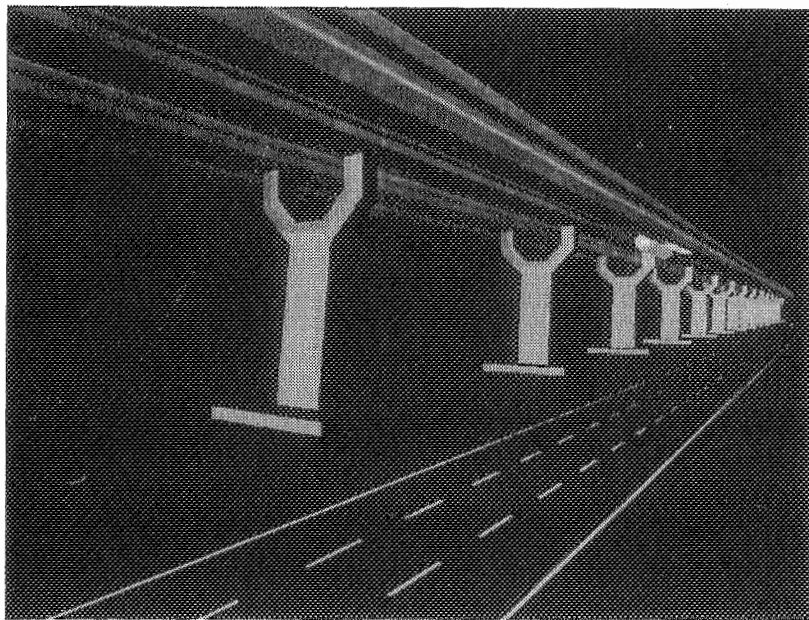

FIGURE 23

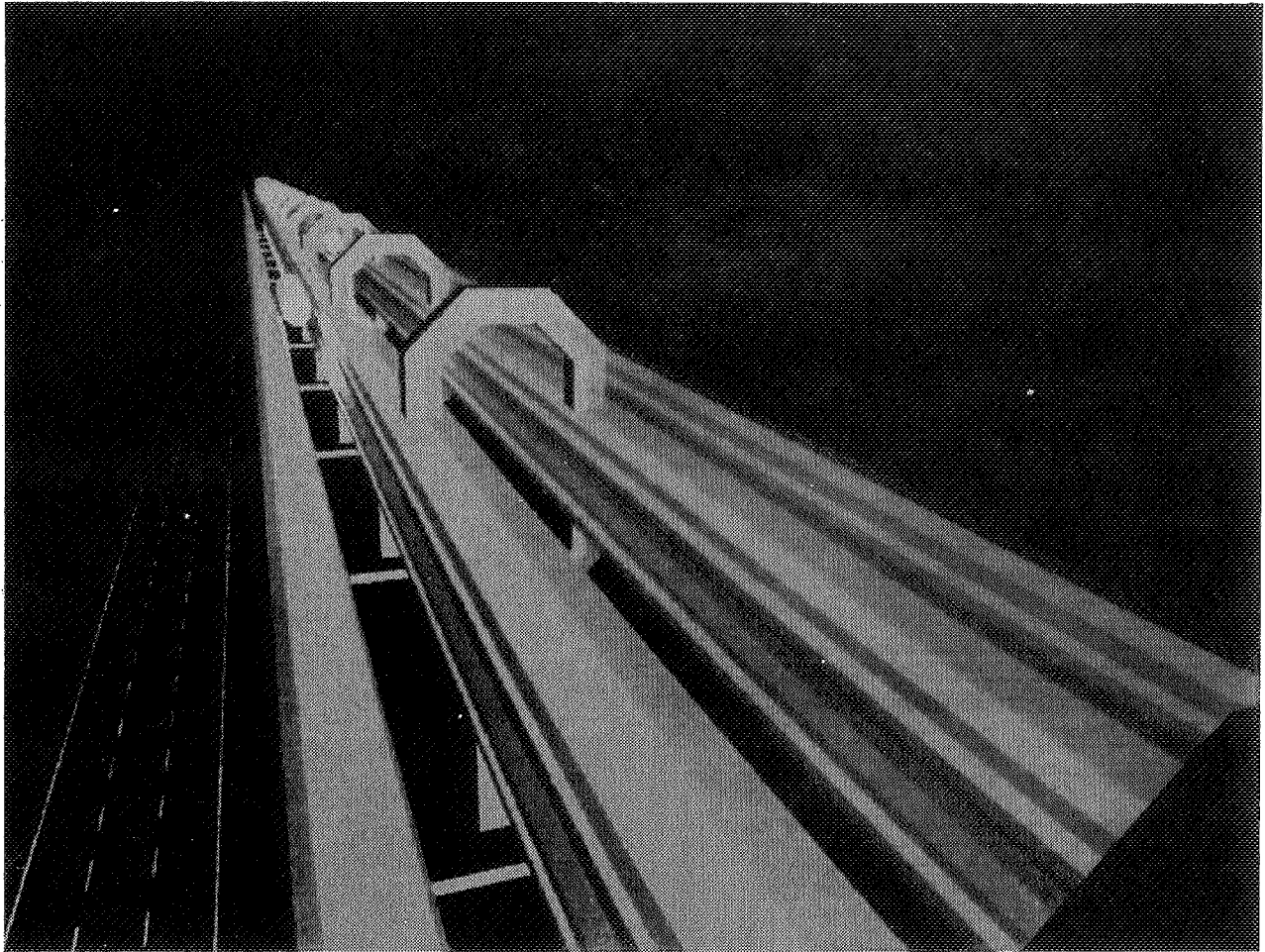

FIGURE 24

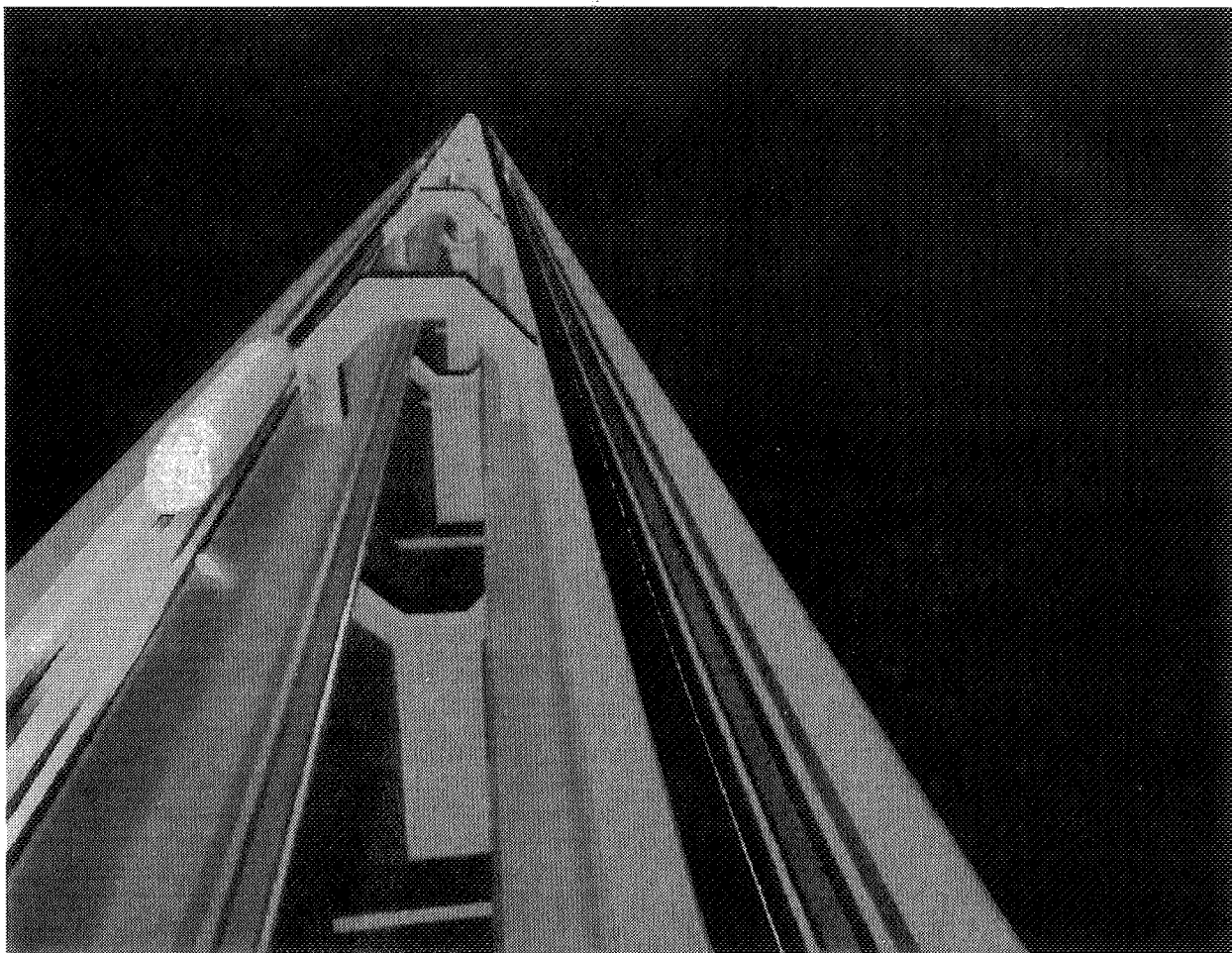

FIGURE 25

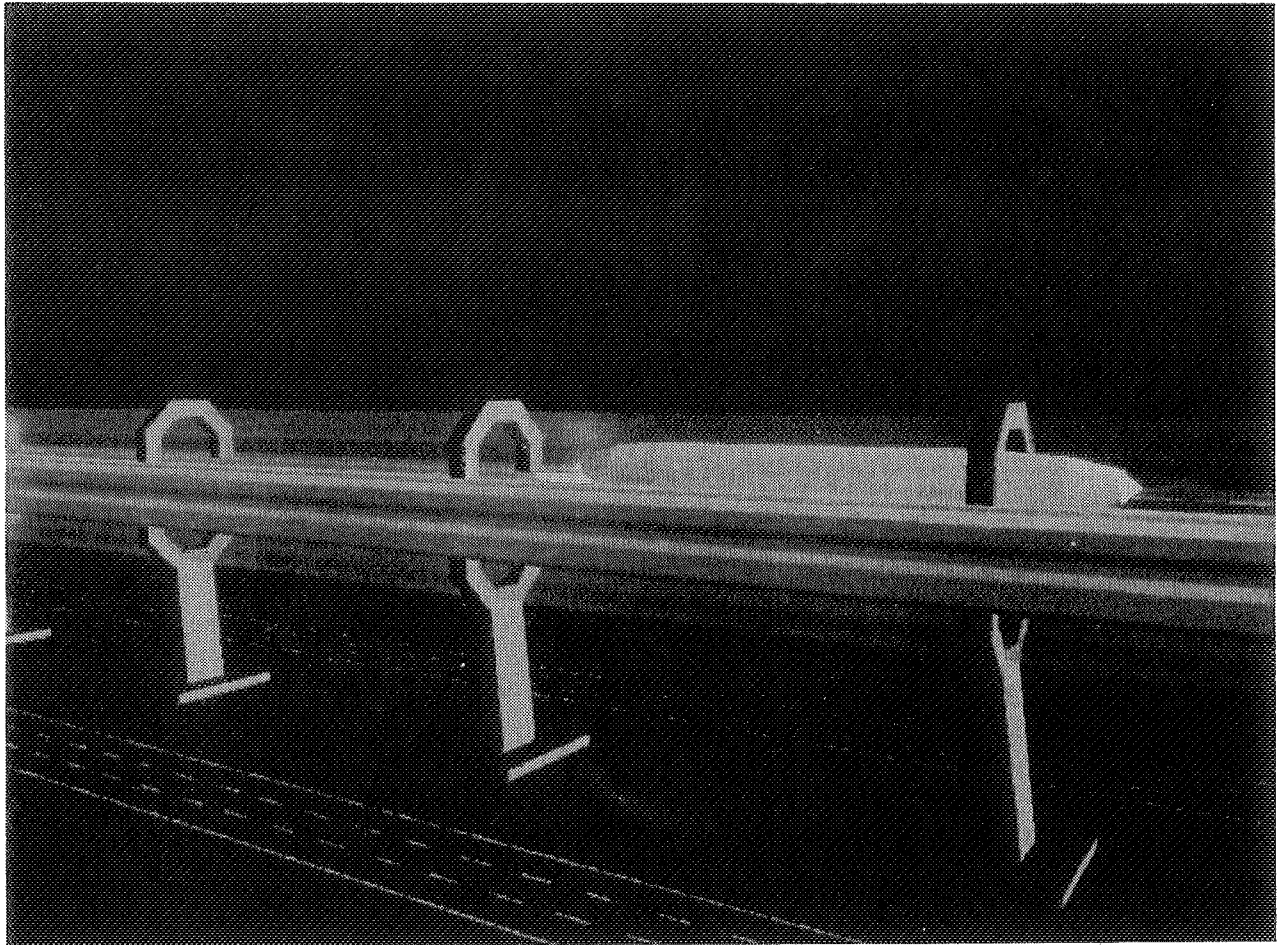

FIGURE 26