

# High Temperature Superconducting Magnets with Active Control for Attraction Levitation Transport Applications

Harry Jones and Richard G. Jenkins  
University of Oxford, Clarendon Laboratory, Oxford OX1 3PU, UK

Roger M. Goodall, Colin Macleod and Abdallah A. El Abbar  
Loughborough University of Technology, Loughborough LEH 3TU, UK

Archie M. Campbell  
University of Cambridge, IRC in Superconductivity, Cambridge CB3 0AE, UK

## SUMMARY

A research programme, involving 3 British universities, directed at quantifying the controllability of High Temperature Superconducting (HTS) magnets for use in attraction levitation transport systems will be described. The work includes measurement of loss mechanisms for iron cored HTS magnets which need to produce a flux density of  $\sim 1$  tesla in the airgap between the magnet poles and a ferromagnetic rail. This flux density needs to be maintained and this is done by introducing small variations of the magnet current using a feedback loop, at frequencies up to 10 Hz to compensate for load changes, track variation etc. The test magnet assemblies constructed so far will be described and the studies and modelling of designs for a practical levitation demonstrator (using commercially obtained HTS tape) will be discussed with particular emphasis on how the field distribution and its components, eg the component vector normal to the broad face of the tape, can radically affect design philosophy compared to the classical electrical engineering approach. Although specifically aimed at levitation transport the controllability data obtained have implications for a much wider range of applications.

## INTRODUCTION

Superconductors for use in levitation transport systems are not new. Probably the most well known system in operation is the test track in Myazaki Prefecture, Kyushu, Japan where for some years, a series of test vehicles with on-board superconducting magnet systems, wound from the conventional Low Temperature Superconductor (LTS) material NbTi, and the associated liquid helium cryogenics are used to produce electrodynamic suspension (EDS) for high speed transportation. This programme is now being extended and sections of track are being built between Tokyo and Osaka for commercial evaluation[1]. High Temperature Superconductors (HTS) are still not sufficiently advanced to play a role in this type of system, in spite of the attractive advantages of their much simpler cryogenic requirements, as the high excitation and flux densities required are not obtainable yet with HTS working at a temperature in the liquid nitrogen regime  $\geq 64\text{K}$ .

Electromagnetic suspension (EMS) systems are another matter however. In these the

ferromagnetic track implicitly restricts the magnetic flux density to  $\sim 1$  tesla. This is normally provided by iron cored, copper wound electro-magnets which provide the lift for low speed vehicles used in "people mover" systems. A good example of these is the one at Birmingham airport, UK which has been in operation for over a decade and is the world's only commercially operating maglev system[2] Here the use of HTS has potential to provide ampere turns whilst retaining the iron core which means that the excitation required and flux density experienced by the superconductor are low enough to stay within the limiting parameters of critical current and critical field presently achievable with state of the art practical conductors (typically tapes) in the LN2 temperature range.

### The Benefits of HTS Coils

At first sight the main advantage of superconducting coils is the zero power requirement when the coils are excited in steady state for lift. For EMS however, the dominating power requirement is in the propulsion system and not in the suspension. The benefits are indirect. For normal coils (Cu or Al) their design is dominated by the thermal aspects and maximum allowable current densities of  $\sim 2-3$  A mm<sup>-2</sup>. These are reflected in the size and weight of the coils and core. With HTS, current densities of  $\sim 10$  A mm<sup>-2</sup> are possible (this is a conservative figure) and this results in a smaller, lighter coil and a reduction in the slot size and therefore the mass of the iron. In a recent paper[3] Goodall et al make some estimates of the impact of HTS on the design of the magnets for the Birmingham Maglev. The relevant parameters are presented in Table 1. From this it is apparent that an increase in lift/weight ratio from 9:1 to 16:1 is possible and this is without any optimisation of the superconducting coil - a topic that will be addressed below.

### The control issues

As a maglev vehicle moves along its track the magnet current, and consequently its inductive and resistive (if any) voltage, must be changed appropriately so that the flux density in the airgap is maintained in order that the vehicle follows the track at low frequencies (1 - 10 Hz) but provides isolation from the high frequency irregularities so that a good ride quality can be achieved. For magnetic suspension, using LTS magnets, the loss mechanisms resulting from these changes would make this approach very difficult as small losses result in big temperature changes at these low temperatures at which specific heat capacities are very small. This brings the risk of "quenching" of the magnets -the sudden transition from superconducting to normal state with huge energy dissipation in the liquid helium. With HTS, conditions, on the face of it, are much less fragile but, although there is some information available on losses in High Tc due to changes in current, virtually no work had been done on iron cored HTS magnets before the work reported here.

### Active magnet control

To our knowledge the approach we propose to achieve control has not been studied before for iron cored superconducting magnets used in maglev. We are advocating direct control of the magnet current in closed loop feedback with sensors (such as search coils or position sensors) that can detect changes in flux resulting from track irregularities. The only other related work seems to be that reported by Kalsi et al[4] in which an LTS magnet working in persistent mode is used to provide the lift but control is achieved using adjacent normal coils. The main feature of our approach is that it involves only HTS coils which fulfill both lift and control functions.

## THE EXPERIMENTAL PROGRAMME

At Loughborough University there has been for some time a demonstration rig which comprises a normal, ie, copper, wound iron cored electromagnet which is mounted at the end of an arm pivoted at its other end. A ferromagnetic rail is positioned above the magnet pole faces and this is mounted on a frame which in its turn is mounted on an independent platform that is capable of being oscillated relative to the magnet. This arrangement permits the demonstration and study of a number of control functions under different conditions. For instance, when the magnet is powered up, it is attracted to the rail and levitates with an airgap of 10 mm and the control electronics can be configured so that when the rail is vertically oscillated the magnet stays where it is or can follow the rail with the air gap being kept constant.

The main aim of this project is to replace the normal coil electromagnet with one incorporating HTS coils and the necessary refrigeration, ie, a LN<sub>2</sub> pool boiling cryostat after an investigation into the loss mechanisms to see which were dominant. The proposed arrangement is shown in Fig. 1.

### The superconductor

At Oxford we have an in-house programme for the development and characterisation of technical HTS superconductors. Over some 5 years, 3 departments, Physics - The Clarendon Laboratory, Materials Science and Engineering Science, have collaborated, and been jointly funded, in investigating a number of routes to produce wires and tapes incorporating BiSrCaCuO superconducting ceramic. Two phases of this are of practical interest; Bi<sub>2</sub>Sr<sub>2</sub>Ca<sub>1</sub>Cu<sub>2</sub>O and Bi<sub>2</sub>Sr<sub>2</sub>Ca<sub>2</sub>Cu<sub>3</sub>O. The first of these is known informally as 2212 BSCCO and has a critical temperature, T<sub>c</sub>, of ~90K, the second is known as 2223 BSCCO and has a T<sub>c</sub> of ~105K. A characteristic feature of most HTS materials is that they only coexist with Ag, to all intents and purposes, so most practical conductors developed so far are composites of the HTS and Ag. At first sight, 2223 BSCCO seems by far the best choice because of its relatively high T<sub>c</sub> and it is indeed preferable. Unfortunately, unlike 2212 BSCCO, it does not lend itself to the partial melt processing which gives good current carrying properties. Rather it has to be mechanically textured and thus the "powder in tube" approach wherein the ceramic powder is packed into a Ag tube and is drawn, rolled and pressed into tapes, has to be used. Because 2212 has good low temperature performance in high magnetic fields there is still an interest in developing it and so at Oxford good progress had been made in producing 2212 tapes by coating methods, ie, electrophoretic coating[5] or dip coating[6] onto Ag tape. The early pancake coils that were used in this work were wound using this in-house produced tape.

*Commercially produced HTS tape.* Meanwhile Intermagnetics General Corporation, IGC, had developed a quality commercial product in 2223 BSCCO tape manufactured by the powder in tube method. We have obtained a batch of this tape and are using it for our second generation coils for the demonstrator magnet which will be described in some detail below. Apart from the good supercurrent carrying capacity of this tape (typically ~15 A at 77K over 100 m, ~30 A over short sample lengths) it can be wound down to 38 mm diameter without strain degradation and probably down to 25 mm with tolerable degradation. This opened up the prospect of our being able to use the "react and wind" route in producing our pancake coils compared to the wind and react method which needs to be employed with most 2212 BSCCO tapes - ie winding the coils out of unreacted tapes and then reacting them, at temperatures on the order of 850 C, with all the inherent technological difficulties.

*Anisotropy in HTS tapes.* One of the inherent drawbacks in the highly textured BSCCO

conductors is that of anisotropic behaviour with respect to ambient magnetic field. The texture is such that the ab plane of the structure lies parallel to the broad face of the tape. It is well established that magnetic field which is normal to the ab plane (or parallel to the c axis.  $B \parallel c$ ) has a much greater effect on the depression of critical current  $I_c$  than that applied parallel. For a set of pancake coils this is good as in the median plane of the solenoid the field lines are indeed parallel to the tape face but at the ends of the coil the radial field component is large and it is this component which is normal to the ab plane. Consequently this aspect has to be taken into account when designing and modelling HTS coils and is probably the biggest departure from classical electrical engineering considerations when designing an HTS / iron electromagnet.

*Measurement of the loss mechanisms* A set of four 2212 coils was used to build two experimental test magnets. The bore of these coils was only 10 mm and the iron circuits had to comply accordingly. The second and best design is shown in Fig 2. In this the back iron is rectangular. Both solid and laminated cores were tried. The main thrust of the experiments with these test magnets was to determine what happened when a small ac current was superimposed on a dc bias current - representing the lift current in a real device - at frequencies from 0 to 100 Hz. This simulates the sort of conditions experienced by an actively controlled magnet in a maglev situation. The results were very clear; the resistive losses were negligible, as might be expected and the HTS losses were also extremely small. The overall losses are dominated by eddy current losses in the core and Ag but these are still insignificant when compared with the total losses in a normal wound magnet under similar conditions. In figure 3 we show an example of the total loss measurement as a function of frequency for both normal and laminated cores. It is worth noting that even at 100 Hz, an order of magnitude greater than that expected in practice, the loss is less than 1 mW. A simple calculation shows that if the coils were made entirely of copper the resistive loss alone, at a dc current of 0.5 A, would be 3.6 mW at all frequencies, ie 4 times that of the dynamic losses of the HTS coils at 100 Hz and two orders of magnitude greater than at a more realistic 10 Hz and this calculation assumes that the copper is at 77K. In practice, the room temperature, or greater, resistivity of the copper would yield at least another order of magnitude difference. Finally, this observation is for a very small test magnet and iron circuit. In fact the dc currents would be more like 10 A so the difference would be even more dramatic between the copper and HTS illustration.

*Coil construction* The pancake modules consist of a pair of pancakes wound in contrary sense on a hat shaped frp former. Pancake to pancake electrical connection is made by axial straps using indium solder at the inner windings. Inter turn insulation is Mylar ribbon ~0.01 mm thick. These double pancake modules are then vacuum impregnated with paraffin wax. Electrical connection between modules is accomplished by straps on the outer turn. More details are given by Jenkins et al[7].

#### The control system

This paper concentrates on the general aspects and those specific to the Oxford partners. The control engineering expertise rests entirely with the Loughborough partners and will not be addressed here, but in a recent paper Goodall and Mcleod[8] deal with these aspects in some detail. Suffice to say the work at Loughborough showed that there are no real problems in achieving the necessary control.

## HTS COILS FOR THE MAGLEV DEMONSTRATOR

Initial performance targets for the maglev demonstrator were that it should generate a flux density of 1T in the 5mm air gaps between 25mm diameter pole pieces and the iron rail, thus producing a lift force of approximately 390N and requiring 8000 ampere-turns.

$$\text{Lift force} = B^2A/2\mu_0 \quad (1)$$

where B is the pole flux density and A is the total area of the poles.

In addition the current density in the windings should exceed 10A/mm<sup>2</sup> (to better the performance of copper coils in the same application) and the iron yoke should be at room temperature.

In designing the HTS coils and iron yoke to meet these requirements we are faced with two important factors:

1) The critical currents of HTS composite tapes are highly sensitive to the magnitude and direction of magnetic field. The anisotropic critical current dependence on applied field for a short sample of IGC tape is shown in Fig. 4. When designing a superconducting magnet incorporating isotropic conductor one is normally concerned only with  $|B|$  which is a maximum at the inner windings on the coil midplane. However, when the coil is to be wound from HTS tape with an anisotropic  $I_c(B)$  one must also take into account the radial component of field (which is perpendicular to the tape surface and therefore in the weak "pinning" direction) which for a simple air-cored solenoid is a maximum at the middle turns at the ends of the coil. Maximum operating current is determined by plotting load lines for peak radial field ( $B_r$ ) and peak axial field ( $B_p$ ) together with the tape critical current as a function of parallel and perpendicular applied fields. An example is shown in Fig 5. In this case it is the  $B_r$  load line and  $I_c(B_{\parallel c})$  which intersect at the lower current, hence it is the radial component of field which determines the maximum operating current of the coil.

2) The presence of iron can greatly alter the field distribution within the windings compared with that found for the same coil(s) in free space (e.g. in the final demonstrator design shown in Fig. 6 the flux over the majority of the coil windings is in the opposite direction to that for the same solenoid with an air core. This has implications for stress in the conductor.) To calculate the field distribution within the HTS windings we used commercial finite element electromagnetic design software.

Thus for each proposed design the calculated field distribution in the windings was compared with the measured critical current data. Although strictly the most important factor in the performance of the final magnet is the total losses, in the design stage it was easier and more practicable to use the criterion that nowhere should the operating current exceed the local critical current.

As a starting point for a coil/yoke design solution we began by looking at an "optimised" conventional arrangement i.e. incorporating copper coils. This is shown in Fig. 7. The ratio of slot depth to width is 1:2, the coils are pole-wound and the windings fill the slot. Fringing at the poles leads to very high flux densities ( $>0.9T$  compared with 1T in the gap) in the "corners" of the windings and renders the geometry unsuitable for HTS.

By lengthening the pole pieces these high fringe fields can be kept away from the coils but the windings are still subjected to unacceptably high perpendicular components (0.25T) due to increased

flux in the now reduced-reluctance path from one pole piece to the other. A better solution is to increase the length of both the pole pieces and the slot, maintaining the same 1:2 ratio. The pole length and slot width were now 60mm and 120mm respectively. From the viewpoint of cryogenic engineering, if the iron is to be at room temperature then this pole-wound configuration is non-ideal, demanding either two simple annular cryostats or one of more elaborate design. This led to a move away from conventional geometry and the positioning of a single coil on the back iron in a single annular cryostat.

In such an arrangement the HTS windings are positioned in a region of relatively low flux density, enabling high lossless currents to be carried. Unfortunately however it does impose limitations on the achievable pole flux densities. As the number of ampere turns on the back of the yoke is increased, the iron in this region is driven into saturation, but the pole flux density remains below around 0.7T. With a 25mm diameter yoke, 60mm pole lengths and a 120mm slot width, we were unable, with a back-wound coil, to generate the target 1T pole flux density; in fact with the available IGC HTS composite tape we were limited to around 0.5T and a lift force of approximately 100 N. Therefore design targets were revised; greatest emphasis was now placed on the generation of 400N lift with the available HTS material.

This target has now been met, and the design is shown in Fig. 8 and its specification in Table 2. The cross section of the iron yoke has increased from 25 to 44 mm diameter, and the increase in pole area has enabled the higher lift force to be achieved. Coil id has also increased, from 37 to 65 mm, thus the risk of any winding strains which would cause degradation in  $I_c$  is totally eliminated.

*Future work:* We propose to scale up an order of magnitude to a 500Kg demonstration "vehicle" with increased emphasis on optimizing with respect to lift/weight ratio. This will in part be achieved by maximizing current densities in the HTS coils, thereby enabling their size to be reduced. Increased  $I_c$  will result from operating at lower temperature possibly using electro-mechanical "cryocoolers" (the IGC conductor at 64K exhibits a critical current approximately 1.6 times larger than that at 77K), and the use of compensation coils to reduce radial field components.

## CONCLUSIONS

This project so far has demonstrated that direct active control of an HTS/iron magnet is easily possible for EMS applications. It has also shown that the magnet design is dictated by the unique characteristics of HTS conductors but with careful optimisation efficient magnets can be produced.

## ACKNOWLEDGEMENTS

The authors gratefully acknowledge the funding provided by the UK's Engineering & Physical Sciences Research Council (GR/J40089). They would also like to pay tribute to the technical skills of Robert Storey for the realisation of some of the hardware. Miss Miriam Avery prepared the final version of this paper and is thanked accordingly.

## REFERENCES

1. Sawada, K.: Development of Magnetically Levitated High Speed Transport System in Japan. Paper presented to 14th International Magnet Technology Conference (MT14), Tampere, Finland 1995. *IEEE Trans. Magn.* In press.
2. Taylor, P.R.D.; Goodall, R.M.; and Oates, C.D.M.: Theoretical and Practical Considerations in the Design of the Suspension System for Birmingham Maglev. *I.Mech.E. Conf. Pub.* 1984-12 paper C14/84, pp 185-192 1984.
3. Goodall, R.; Macleod, C.; El-Abbar, A.A.; Jones, H.; Jenkins, R.; and Campbell, A.: The potential for EMS Maglev using High Temperature Superconductors. *Proc. Maglev '95 Bremen, Germany.*
4. Kalsi, S.; Proise, T.; Schulthüss.; and Dawkins, B.: Iron Core Superconducting Magnet Design and Test Results for Maglev Application. *IEEE Trans. Appl. Supercond.*, 5, (1995) pp 964-967.
5. Yang, Ming.; Goringe, M.J.; Grovenor, C.R.M.; Jenkins, R.; and Jones, H.: The Fabrication of Bi-based Superconductor Tape by Electrophoretic Deposition and Melt-Texturing Techniques. *Supercond. Sci. Technol.* 7 (1994) 378-388.
6. Burgoyne, J.W.; Eastell, C.; Morgan, C.G.; East, D.; Jenkins, R.G.; Young, M.; Dew-Hughes, D.; Jones, H.; Grovenor, C.R.M.; and Goringe, M.J.: A Novel Continuous Process for the Production of Long Lengths of BSCCO-2212/Ag Dip Coated Tape. Proc. EUCAS Edinburgh July 1995. IOP Conference Series *Applied Superconductivity* 1995 - in press.
7. Jenkins, R.G.; Jones, H.; Young, M.; Belenli, I.; Grovenor, C.R.M.; and Goringe, M.J.: Prototype Coils Wound from High Tc Superconducting Composites. *Paper 259 Proc. MT13 IEEE Trans. Mag.* 30 (1994) 1813-1816.
8. Goodall, R.M.; and Macleod, C.: Control Considerations Relating to the use of Superconducting Coils in Maglev Suspensions. *IEEE Conf. on Control and its applications (CCA '95).* Albany NY Sept. 1995.

**Table 1. Comparison of Normal and HTS Coils with reference to the Birmingham Maglev**

	Normal	HTS
Current density	2 - 3 A mm <sup>-2</sup>	10 A mm <sup>-2</sup> <sup>(1)</sup>
Packing factor	0.5	0.5
Slot size	230 x 115 mm	100 x 50 mm
Mass of core	59 kg	37 kg
Total magnet mass	112 kg	63 kg <sup>(2)</sup>
Lift/weight ratio	9:1	16:1

(1) Conservative figure but makes some allowance for cryostat. (2) Estimate assuming coil is entirely Ag

**Table 2. Coil Data and Performance for Maglev Demonstrator**

<u>Coil Data</u>		<u>Performance @ I = 5A</u>	
No. of double pancake modules:	9	ampere turns (nI):	4770
total no. of turns:	954	Bgap from 3D model:	0.54 T
inner winding diam.:	65 mm	Bgap from simple calc: ( $B = \mu_0 nI/g$ )	0.60 T
outer winding diam.:	95.6 mm		
length:	90 mm	lift force ( $B^2A/2\mu_0$ ):	449 N
overall turns density:	80 cm <sup>-2</sup>		
operating temp.:	77.3 K		
max. operating I (Ic):	5 A		



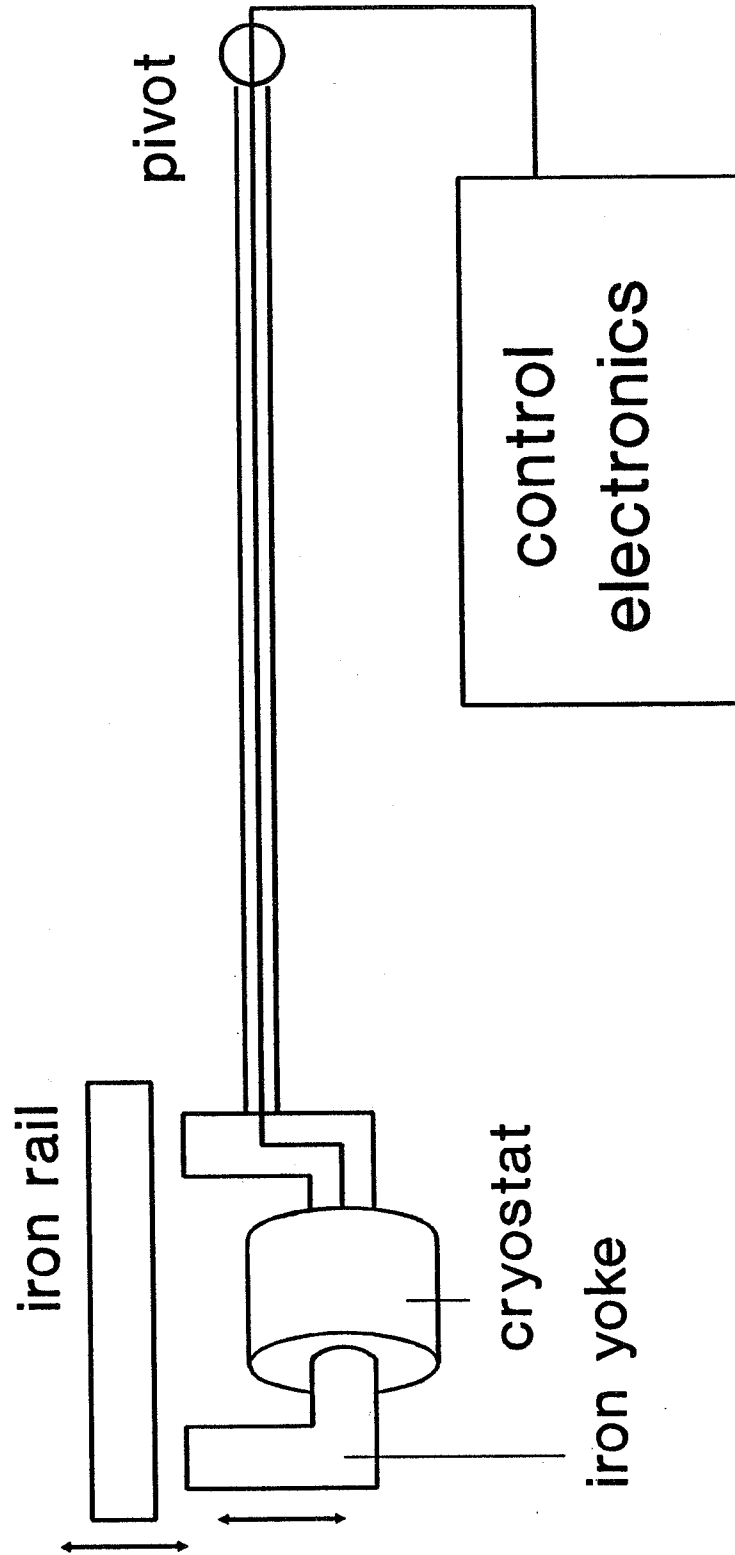

Figure 1. The maglev demonstrator incorporating HTS coils. Control of magnet current enables suspension of the iron yoke (attached to a hinged support arm) beneath a moving section of rail.

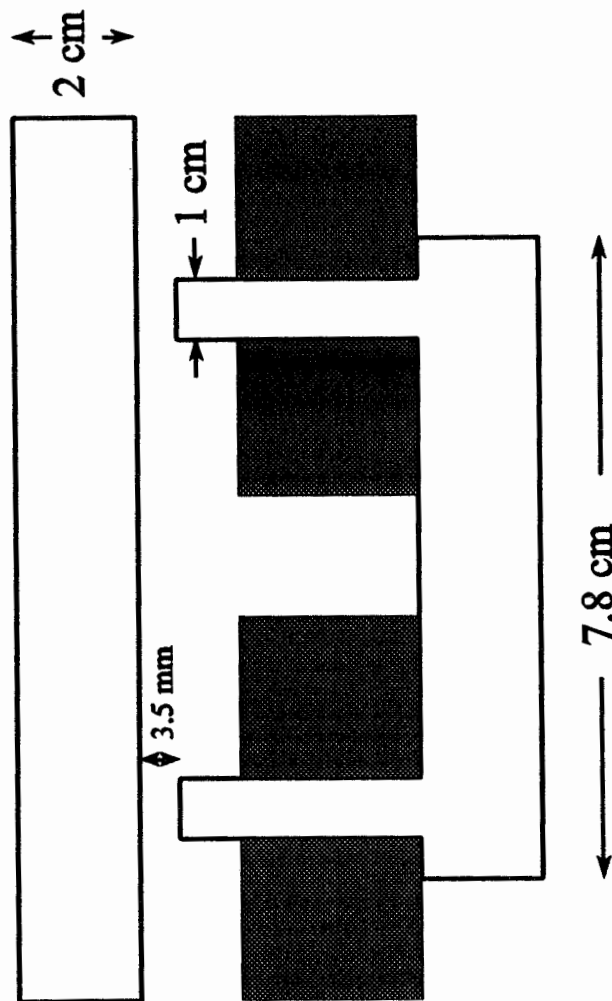

Figure 2. The improved version of the experimental magnet for loss investigations. The back iron is rectangular. Both solid and laminated versions of the iron circuit were made.

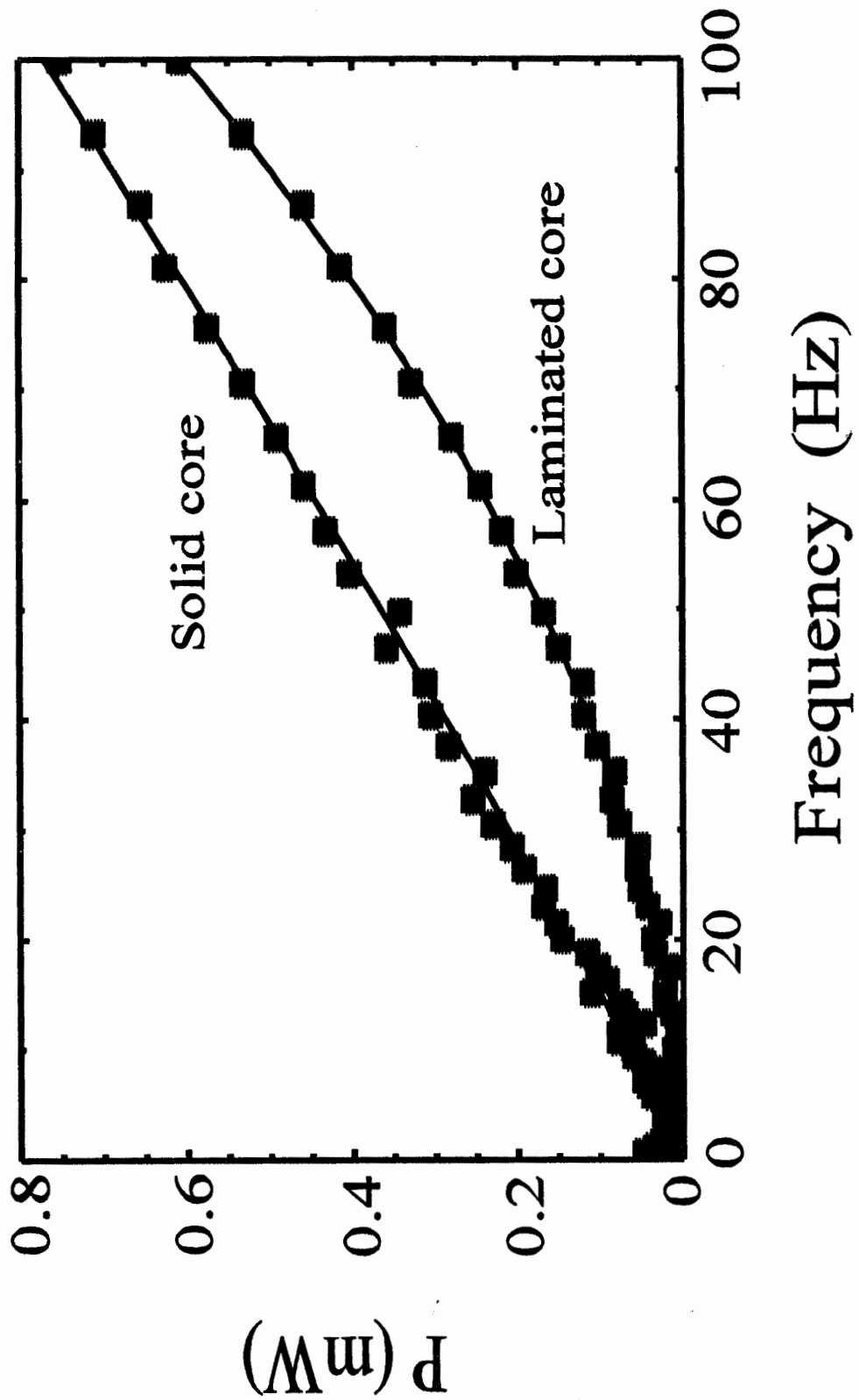

Figure 3. Losses (in mW) vs frequency for a superimposed ac current of 0.04 A (rms) on a 0.5 A d.c. current for the test magnet shown in Figure 2.

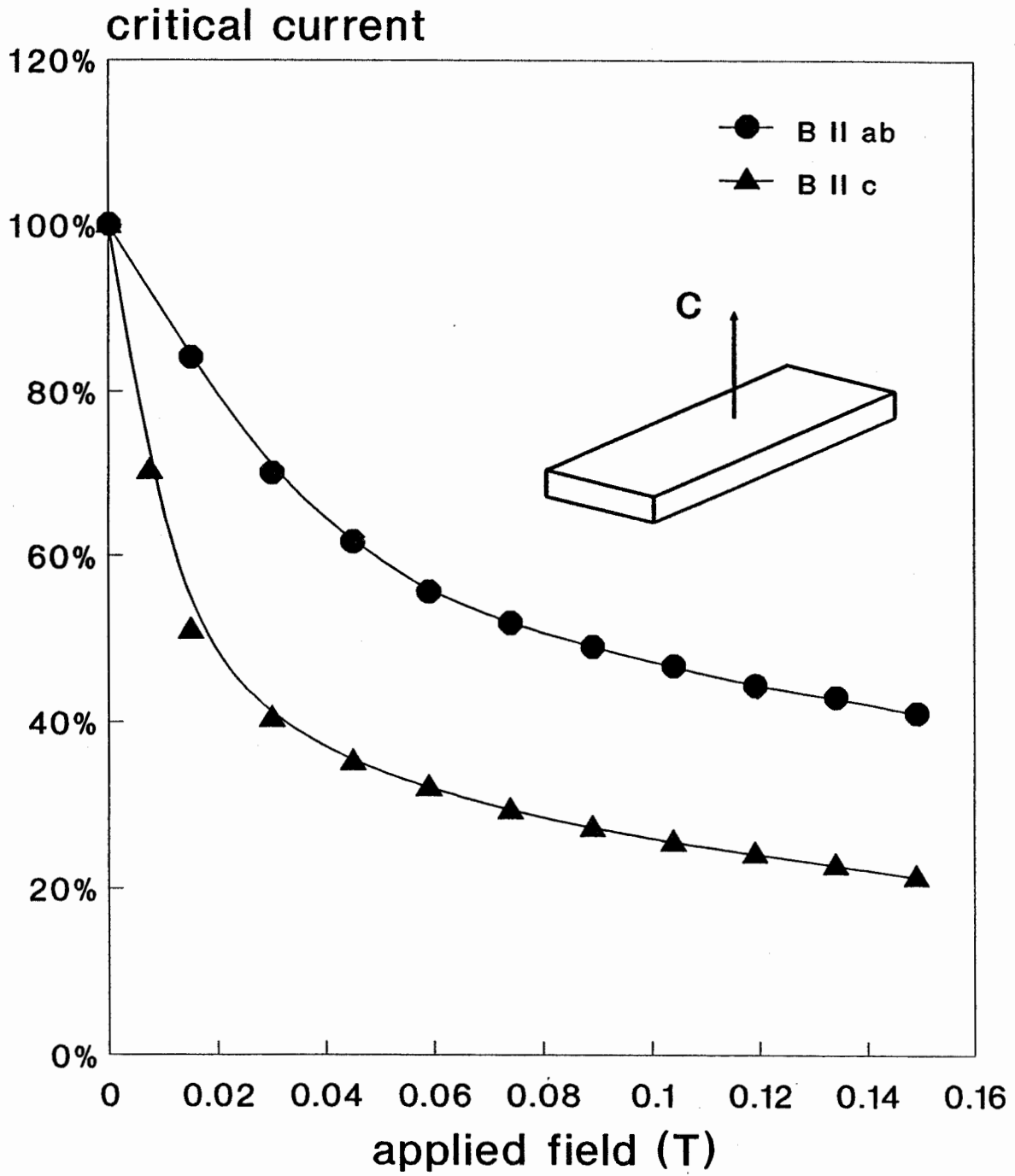

Figure 4. Normalised critical current at 77.3 K as a function of applied magnetic field for a short sample of IGC HTS tape from which the maglev demonstrator coils will be wound.

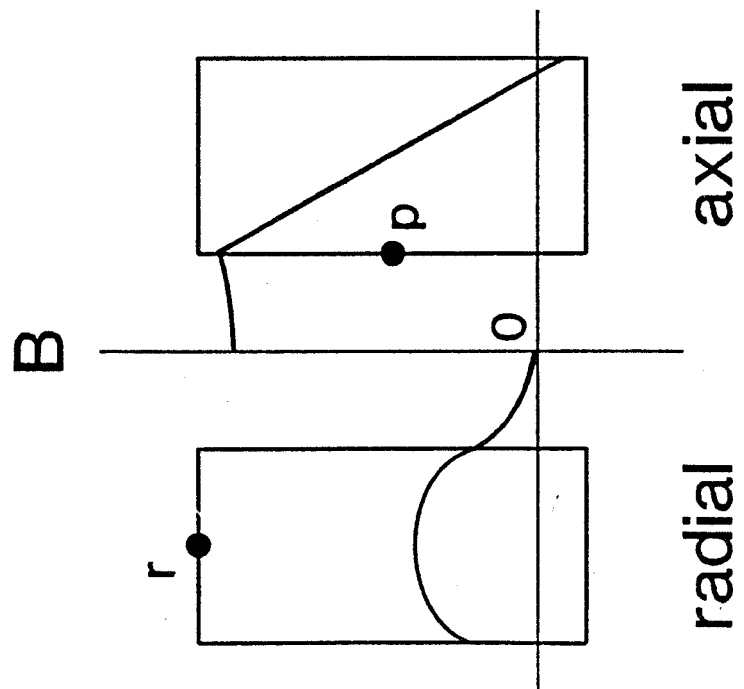
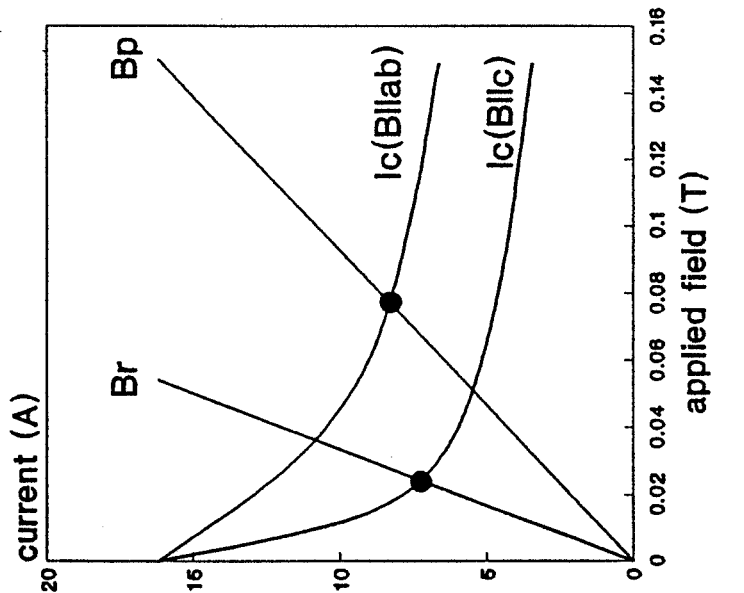

Figure 5. Axial and radial field profiles in the windings of a simple solenoid: peak values occur at points p and r respectively. Load lines plotted with anisotropic  $I_c(B)$  data show that for this example it is the radial component which limits the maximum operating current of the magnet.

UNITS	
Length	: cm
Flux density	: gauss
Magnetic field	: oersted
Scalar potential	: oersted-cm
Vector potential	: gauss-cm
Conductivity	: S cm <sup>-1</sup>
Current density	: A cm <sup>-2</sup>
Power	: W
Force	: N
Energy	: J
Electric field	: V cm <sup>-1</sup>

PROBLEM DATA	
FINALY.TSB	
TOSCA analysis (nl)	
Case No	1
16368 elements	
18459 nodes	
Shape funct. fields	
Nodal coil fields	

LOCAL COORDS.	
Xlocal	= 0.0
Ylocal	= 0.0
Zlocal	= 0.0
Theta	= 0.0
Phi	= 0.0
Psi	= 0.0

06/Dec/95 14:39:28 Page 12
----------------------------



Post-processor 2.5

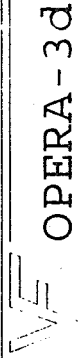
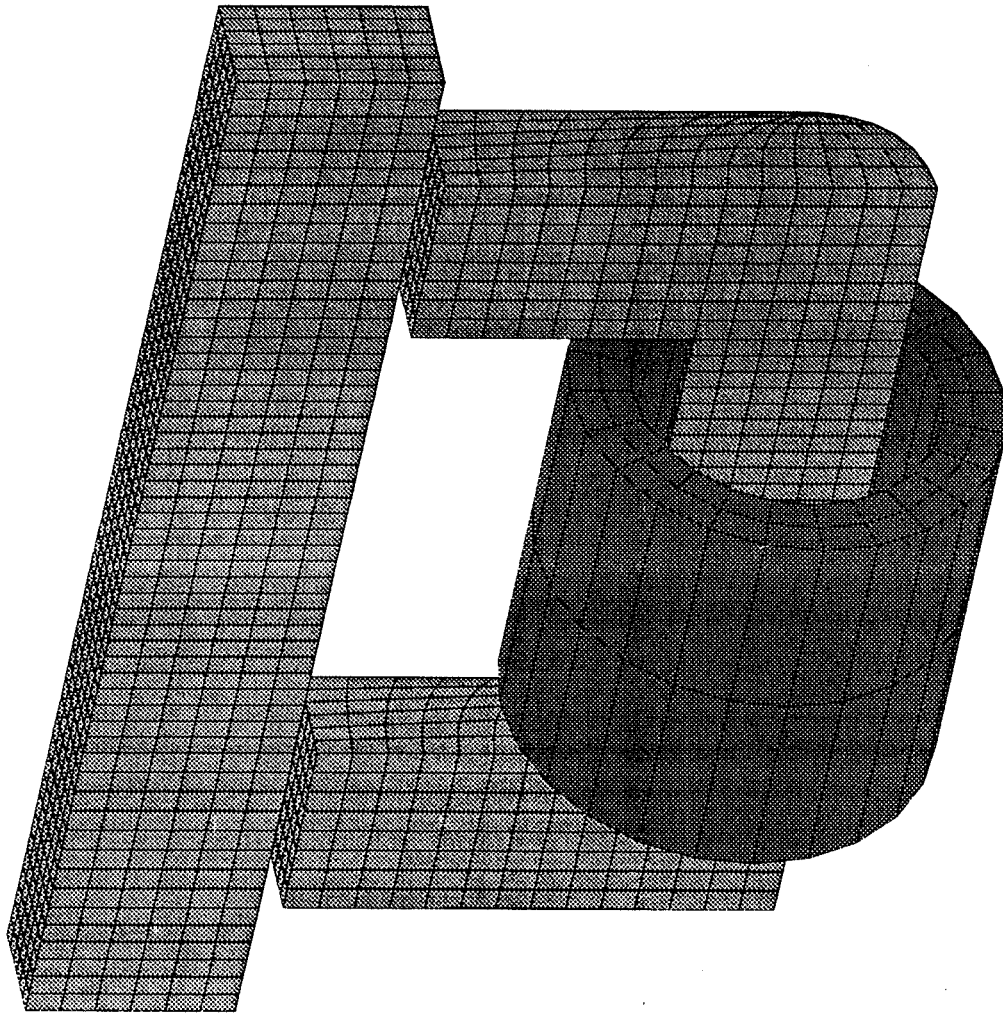

Figure 6. The final design for the iron yoke and HTS coil for the maglev demonstrator. Only half of the yoke and rail are shown, divided into elements for modelling.

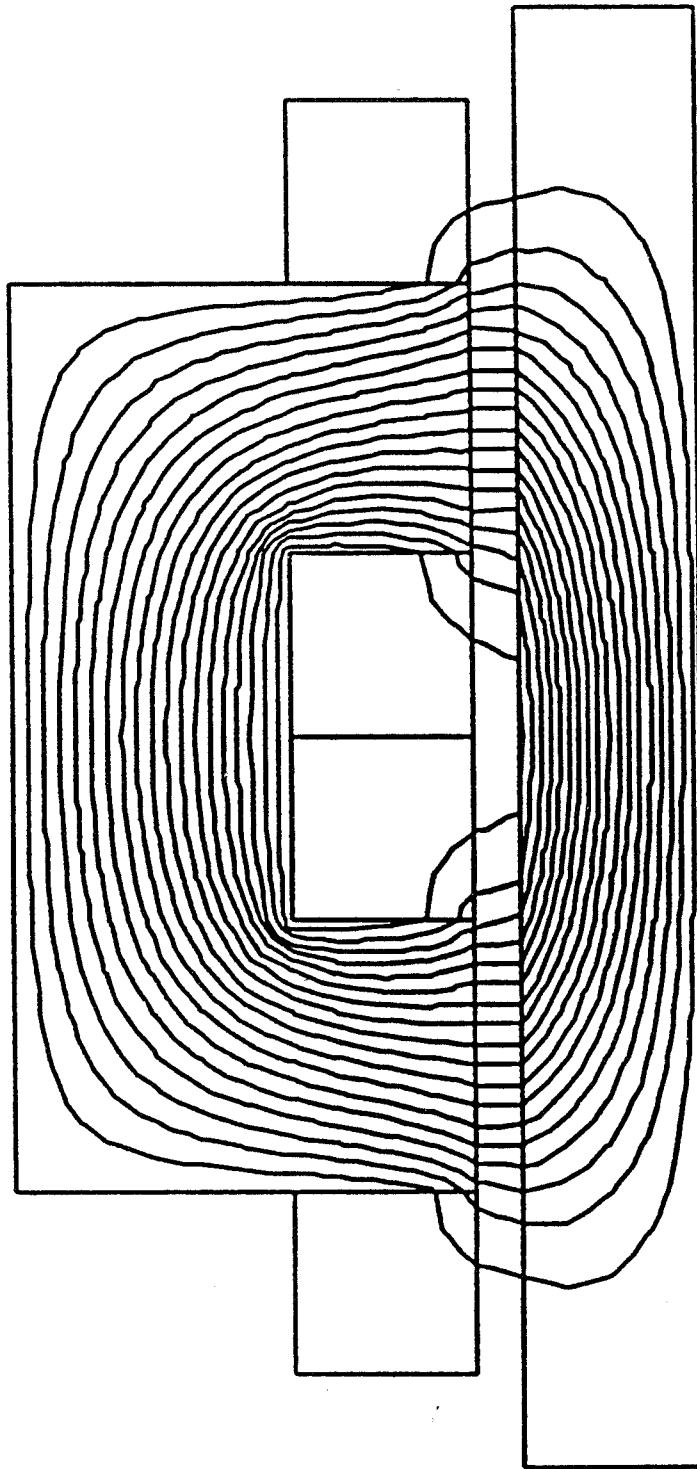

Figure 7. Flux distribution in a conventional maglev demonstrator design incorporating pole-wound coils. Fringing at the poles makes this geometry unsuitable for HTS windings.

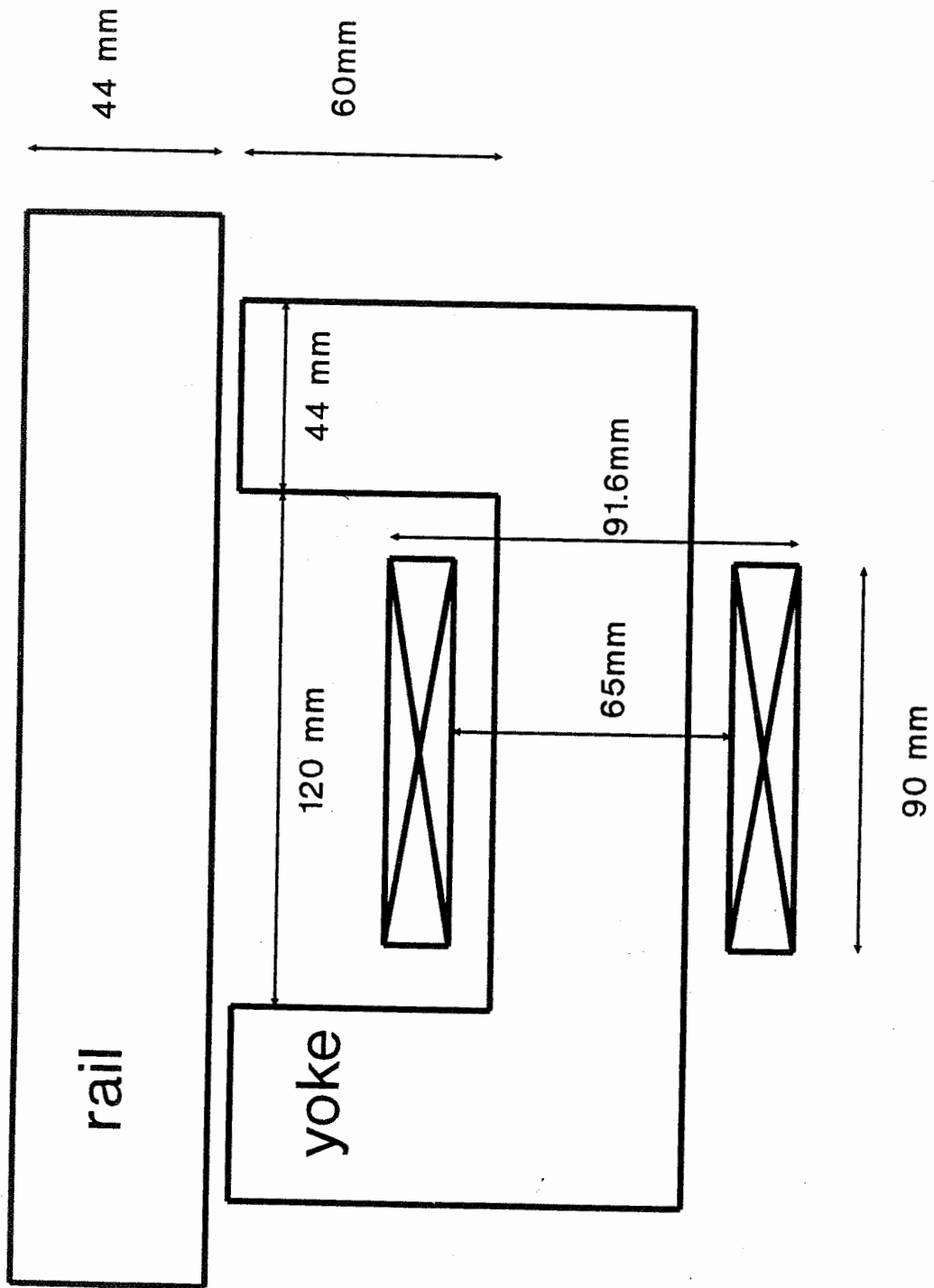

Figure 8. Cross section of the HTS coil and iron yoke for the demonstrator.