

511-63  
82148-  
235615

## DESIGN OF ROBUST ADAPTIVE UNBALANCE RESPONSE CONTROLLERS FOR ROTORS WITH MAGNETIC BEARINGS

14p.

Carl R. Knospe  
Samir M. Tamer  
Stephen J. Fedigan  
Department of Mechanical, Aerospace and Nuclear Engineering  
University of Virginia  
Charlottesville, Virginia, 22903

### ABSTRACT

Experimental results have recently demonstrated that an adaptive open loop control strategy can be highly effective in the suppression of unbalance induced vibration on rotors supported in active magnetic bearings. This algorithm, however, relies upon a predetermined gain matrix. Typically, this matrix is determined by an optimal control formulation resulting in the choice of the pseudo-inverse of the nominal influence coefficient matrix as the gain matrix. This solution may result in problems with stability and performance robustness since the estimated influence coefficient matrix is not equal to the actual influence coefficient matrix. Recently, analysis tools have been developed to examine the robustness of this control algorithm with respect to structured uncertainty. Herein, these tools are extended to produce a design procedure for determining the adaptive law's gain matrix. The resulting control algorithm has a guaranteed convergence rate and steady state performance in spite of the uncertainty in the rotor system. Several examples are presented which demonstrate the effectiveness of this approach and its advantages over the standard optimal control formulation.

### INTRODUCTION

The active control of unbalance vibration in rotating machinery using magnetic bearings has generated a great deal of interest in the last decade [1-10]. Recently, research in this area has focused on the application of adaptive open loop (or feedforward) strategies. This type of control has the advantage of not placing any constraint on the design of the stabilizing feedback control loop for the rotor. Thus, the transient performance of the machine can be optimized without considering its unbalance response.

An important issue in the application of the adaptive open loop control (AOLC) to industrial machines is the stability and performance robustness of the unbalance control algorithm employed. Recently, the authors have demonstrated that the stability and performance robustness of an AOLC algorithm can be analyzed using structured singular value methods [11]. In this paper, these methods are extended to provide a synthesis procedure for the design of the AOLC gain matrix. Several examples are

presented which demonstrate the effectiveness of the design procedure and its advantage over the standard approach that uses a gain matrix derived from optimal control theory.

### Mathematical Notation

The two-norm of a vector  $v$  is indicated by the notation  $\|v\|$ . The maximum singular value of a matrix  $P$  is denoted by  $\bar{\sigma}(P)$  and the spectral norm by  $\rho(P)$ . The lower and upper linear fractional transformations [12] of  $P$  are given the notations  $\mathcal{F}_l(P, Q)$  and  $\mathcal{F}_u(P, R)$  respectively where the matrices  $Q$  and  $R$  are assumed to be appropriately dimensioned. The Redheffer star-product [13] of appropriately dimensioned matrices  $P$  and  $Q$  will be denoted by  $S(P, Q)$ . The structured singular value [12,14] of a matrix  $P$  is indicated by the notation  $\mu_\Delta(P)$ . The symbol  $S_\Delta$  is used to denote the set of all matrices of a defined block structure.

### ADAPTIVE OPEN LOOP CONTROL

Adaptive open loop control has been shown to provide excellent vibration attenuation over an operating speed range, to quickly respond to sudden changes in unbalance, and to be computationally simple [10].

The concept of adaptive open loop control is quite simple. Synchronous perturbation control signals are generated and added to the feedback control signals. The magnitudes and phases of these sinusoids are periodically adjusted so as to minimize the rotor unbalance response. In this paper, a particular form of adaptive open loop control, referred to as *convergent control*, will be examined. The convergent control algorithm uses a model of the rotor system where vibration is related to the applied open loop signals via

$$X = TU + X_0$$

where  $X$  is a  $n$ -vector of the complex synchronous Fourier coefficients of the  $n$  vibration measurements,  $U$  is a  $m$ -vector of the complex synchronous Fourier coefficients of the  $m$  applied open loop signals,  $X_0$  is a  $n$ -vector of the complex synchronous Fourier coefficients of the uncontrolled vibration, and  $T$  is a  $n \times m$  matrix of complex influence coefficients relating the open loop signals to the vibration measurements. The influence coefficient matrix is the transfer function matrix of the supported rotor (with feedback control) from perturbation forces at the bearings to the displacements at the sensors, evaluated at the rotor operating speed  $\Omega$ ,

$$T = G_{f \rightarrow d}(j\Omega) = \mathbf{C}(j\Omega\mathbf{I} - \mathbf{A})^{-1}\mathbf{B} + \mathbf{D}$$

where the rotor/bearing system is described by the state space model  $(\mathbf{A}, \mathbf{B}, \mathbf{C}, \mathbf{D})$ :

$$G_{f \rightarrow d}(s) = \left[ \begin{array}{c|c} \mathbf{A} & \mathbf{B} \\ \hline \mathbf{C} & \mathbf{D} \end{array} \right]$$

Since the convergent control algorithm updates the control vector  $U$  periodically, the subscript  $i$  will be used to denote the  $i$ 'th update. The time between the  $i$ 'th and  $i+1$ 'th update is referred to as cycle  $i$  of the algorithm. During cycle  $i$ , the control  $U_i$  is applied resulting in the vibration  $X_i$ . This vibration vector is computed during cycle  $i$  using the measurements from the position sensors. The vibration vector is related to the control vector by

$$X_i = TU_i + X_{0i} \quad (1)$$

where  $T$  is assumed to be changing slowly and therefore is not subscripted. During cycle  $i$  the next update of the control vector  $U_{i+1}$  must be computed from the available information (i.e.,  $U_i$  and  $X_i$ ). Convergent control uses the control update or *adaptation* law

$$U_{i+1} = U_i + AX_i \quad (2)$$

where  $A$  is a gain matrix. The standard approach for determining the gain matrix  $A$  is through the formulation of an optimal control problem. Minimizing the quadratic performance function

$$J = E\{X_{i+1}^* X_{i+1}\} \quad (3)$$

where  $E\{\}$  is the expected value operator, results in the optimal gain matrix [10]

$$A \equiv -[T^*T]^{-1}T^* \quad (4)$$

For implementation, the matrix  $T$  for a particular operating speed can be estimated either on-line or off-line. When on-line estimation is employed, the gain matrix  $A$  is based upon a recently measured influence coefficient matrix. If the estimator can track the changes in this matrix, the estimate will be accurate and the robustness of the algorithm is not an important issue. However, as the authors have experimentally demonstrated [10], the use of continuous on-line estimation may result in large synchronous response when there is a sudden change in rotor speed or unbalance.

An off-line estimate may be obtained through either (1) the injection of test forces using the bearings, or (2) modeling of the machine's dynamics (rotor, amplifiers, sensors, and feedback controller). Either of these estimates,  $\hat{T}$  can be considered to correspond to a nominal state space model of the system given as follows

$$\bar{G}_{f \rightarrow d}(s) \equiv \left[ \begin{array}{c|c} \bar{A} & \bar{B} \\ \hline \bar{C} & \bar{D} \end{array} \right]$$

where the estimate is related to this nominal model via the equation

$$\hat{T} = \bar{G}_{f \rightarrow d}(j\Omega)$$

If the influence coefficient matrix estimate is used to compute the gain matrix  $A$ , the *nominal system optimal gain matrix* results

$$A_{nso} = -[\hat{T}^* \hat{T}]^{-1} \hat{T}^* \quad (5)$$

Because of the possible inaccuracy of the off-line determined estimate, the robustness of the algorithm must be considered. With sufficient error, the nominal system optimal gain matrix may result in unstable adaptation. In this paper, an alternative design method is proposed for the determination of the gain matrix  $A$ . This method results in a gain matrix which has a worst case performance that is guaranteed to be within a specified factor of the optimal performance.

The best synchronous performance that can be obtained through active control (open loop or feedback) as measured by the minimum value of the quadratic performance index denoted  $J_{opt}$  is

$$J_{opt} = X_{opt}^* X_{opt}$$

where the minimal vibration vector  $X_{opt}$  is given by the expression

$$X_{opt} = [I - T(T^*T)^{-1}T^*]X_o$$

When the estimate used in the adaptation of the control schedule,  $\hat{T}$ , is equal to the actual influence coefficient matrix,  $T$ , this performance is achieved by the convergent control algorithm (with  $A$  given by Eqn. 5) in one update. When the estimate is in error, the adaptation process, governed by Eqns. (1) and (2), results in the control vector either growing unbounded or converging to a control vector  $U_n$  that may not be equal to the optimal control vector. If the control vector converges to an equilibrium vector  $U_n$ , then the adaptation process is said to be stable. A necessary and sufficient condition for stability is  $\rho(I + AT) < 1$ . A sufficient condition for adaptation process stability is given by the following condition [9]:

$$\bar{\sigma}(I + AT) < 1 \quad (6)$$

This stability condition requires that the distance of the control vector from the equilibrium control vector,  $\|U_i - U_n\|$ , decrease with each update. This more conservative condition, exponential convergence, is required to obtain an upper bound on worst case performance. Therefore, Eqn. (6) will be used as the stability criterion throughout this paper. If the adaptation process is stable, the steady state value of the vibration vector is given by

$$X_n = [I - T(AT)^{-1}A]X_{opt} \quad (7)$$

## ROBUSTNESS

In application of the algorithm, only an estimate of the matrix  $T$  can be used in determining the gain matrix  $A$ . If this estimate,  $\hat{T}$ , was obtained through testing, it may differ from the actual  $T$  due to

inaccuracies in the estimation process, and/or to changes in the machine's dynamics since the estimate was obtained. If the estimate was obtained from a computer model of the rotor, it may differ due to modeling errors.

Both changes in the machine's dynamics and modeling errors usually can be represented by a structured uncertainty representation. That is, several parameters  $\theta_1, \theta_2, \dots, \theta_i, \dots, \theta_p$  of the dynamic model (e.g., the effective stiffness or damping of a seal) are different from those that produced the influence coefficient estimate  $\hat{T}$ . Furthermore, a structured representation of uncertainty indicates how each of these parameter affects the elements of the influence coefficient matrix  $T$ . Each parameter  $\theta_i$  may differ from its nominal value  $\bar{\theta}_i$  (i.e., the value which produced the estimate  $\hat{T}$ ) with this difference bounded as follows

$$\theta_i = \bar{\theta}_i + \delta_i \quad |\delta_i| \leq d_i$$

Thus, each parameter remains in some known neighborhood about its nominal value. Each of these parameters may be either real or complex, and therefore this neighborhood may be either a real interval or a complex "ball" centered on the nominal value.

If the state space model matrices ( $\mathbf{A}, \mathbf{B}, \mathbf{C}, \mathbf{D}$ ) are affinely dependent on the uncertain parameters  $\delta_1, \delta_2, \dots, \delta_i, \dots, \delta_p$ , then the influence coefficient matrix of the rotor/bearing system can be represented by a linear fractional transformation (LFT) of the following form [11]

$$T = \mathcal{F}_u(G(j\Omega), \Delta_s) \equiv G_{22}(j\Omega) + G_{21}(j\Omega)\Delta_s[I - G_{11}(j\Omega)\Delta_s]^{-1}G_{12}(j\Omega)$$

where the nominal influence coefficient matrix is given by

$$G_{22}(j\Omega) = \bar{G}_{f \rightarrow d}(j\Omega) = \hat{T}$$

and  $\Delta_s$  is a block diagonal matrix of the uncertain parameters. The uncertainties considered determine the particular block structure. The set of all matrices of a given block structure is denoted by  $S_\Delta$ . Note that through appropriate scaling of the matrices  $G_{11}(j\Omega)$  and  $G_{12}(j\Omega)$ , the uncertain parameters can all be considered to satisfy

$$|\delta_i| \leq 1$$

Throughout the remainder of this paper, the notation  $(j\Omega)$  will be suppressed. It will be understood that  $G_{ij}$  represents a transfer function matrix evaluated at the operating speed of the rotor.

### Stability Robustness

The adaptation process is said to have exponential convergence to steady state control vector  $U_n$  with convergence rate  $\varepsilon_c$  if

$$\|U_{i+1} - U_n\| \leq \varepsilon_c \|U_i - U_n\|$$

This is achieved for all  $T$  given by the family of matrices

$$T = \mathcal{F}_u(G, \Delta_s) \quad \Delta_s \in \mathcal{S}_{\Delta_s}: \bar{\sigma}(\Delta_s) \leq 1 \quad (8)$$

if and only if  $\mu_{\Delta}(\mathbf{S}_a) < 1$  where

$$\mathbf{S}_a \equiv \mathbf{S}(G, V) \quad V \equiv \begin{bmatrix} 0 & I \\ \frac{1}{\varepsilon_c} A & \frac{1}{\varepsilon_c} I \end{bmatrix} \quad (9)$$

and the uncertainty structure is given by

$$\Delta = \begin{bmatrix} \Delta_s & \\ & \Delta_f \end{bmatrix}$$

where  $\Delta_s$  is a structured block representing the parametric uncertainty,  $\Delta_s \in \mathcal{S}_{\Delta_s}$ , and  $\Delta_f$  is a full complex block,  $\Delta_f \in \mathcal{C}^{m \times m}$  [11].

### Performance Robustness

As discussed previously, an error in the influence coefficient estimates may cause a decrease in performance (unbalance response attenuation). Performance is measured using a quadratic performance index of the steady state vibration

$$J_n \equiv X_n^* X_n = \|X_n\|^2 \quad (10)$$

As shown by the authors [11], the steady state performance for an uncertain rotor system given by Eqn. (8) is bounded as follows

$$J_n < \kappa^2 J_{opt} \quad (11)$$

where

$$\kappa = \beta + v \vartheta \bar{\sigma}(A) \frac{\vartheta}{\alpha - \vartheta} \quad (12)$$

In this equation,  $\alpha$  is a free parameter ( $\alpha > \vartheta$ ), and  $\beta$ ,  $v$ , and  $\vartheta$  are given by the expressions

$$\beta \equiv \left\{ \min_{\gamma > 0} \gamma: \mu_{\Delta}(\mathbf{S}(G, W)) < 1, W \equiv \begin{bmatrix} \alpha A & A \\ \frac{\alpha}{\gamma} I & \frac{1}{\gamma} I \end{bmatrix}, \Delta = \begin{bmatrix} \Delta_s & \\ & \Delta_f \end{bmatrix}, \Delta_f \in \mathcal{C}^{n \times n} \right\} \quad (13a)$$

$$v \equiv \left\{ \min_{\gamma > 0} \gamma : \mu_{\Delta} \left( \begin{bmatrix} G_{11} & G_{12} \\ \frac{1}{\gamma} G_{21} & \frac{1}{\gamma} G_{22} \end{bmatrix} \right) < 1, \Delta = \begin{bmatrix} \Delta_s & \\ & \Delta_f \end{bmatrix}, \Delta_f \in C^{m \times n} \right\} \quad (13b)$$

$$\vartheta \equiv \left\{ \frac{1}{1 - \min_{0 < \gamma < 1} \gamma} : \mu_{\Delta}(\mathbf{S}(G, V)) < 1, V \equiv \begin{bmatrix} 0 & I \\ \frac{1}{\gamma} A & \frac{1}{\gamma} I \end{bmatrix}, \Delta = \begin{bmatrix} \Delta_s & \\ & \Delta_f \end{bmatrix}, \Delta_f \in C^{m \times m} \right\} \quad (13c)$$

As Eqn. (12) indicates, the variable  $\kappa$  can be decreased so that it is very close to the value of  $\beta$  through increasing  $\alpha$ . For large  $\alpha$ ,  $\beta$  can be considered a good approximation to  $\kappa$ . If this approximation holds, then  $\mu_{\Delta}(\mathbf{S}(G, W)) < 1$  implies that  $J_n < \beta^2 J_{opt}$ . The derivation of Eqn. (12) requires that the stability condition, Eqn. (6), be satisfied.

### Convergence Rate and Performance

Both a convergence rate of  $\varepsilon_c$  and an (approximate) performance of  $J_n < \beta^2 J_{opt}$  can be "guaranteed" if the following condition holds

$$\mu_{\Delta}(\bar{\mathbf{S}}) < 1 \quad \bar{\mathbf{S}} \equiv \begin{bmatrix} \mathbf{S}(G, V) & \\ & \mathbf{S}(G, W) \end{bmatrix} \quad (14)$$

where the structure of the uncertainty block  $\Delta$  is given by

$$\Delta = \begin{bmatrix} \Delta_s^1 & & & \\ & \Delta_f^1 & & \\ & & \Delta_s^2 & \\ & & & \Delta_f^2 \end{bmatrix} \quad \begin{array}{l} \Delta_s^1, \Delta_s^2 \in \mathcal{S}_{\Delta_s} \\ \Delta_f^1 \in C^{m \times m} \\ \Delta_f^2 \in C^{n \times n} \end{array} \quad (15)$$

where  $V$  and  $W$  are as defined in Eqns. (9) and (13a). Note that both  $V$  and  $W$  in Eqn. (14) are affinely dependent on the gain matrix  $A$ .

An upper bound on the structured singular value  $\mu$  is available via the equation

$$\mu_{\Delta}(\bar{\mathbf{S}}) \leq \left\{ \min_{\substack{\mathcal{D}_L, \mathcal{D}_R, \tilde{q} \\ \mathcal{G}_L, \mathcal{G}_M, \mathcal{G}_R}} q : q \equiv \bar{\sigma} \left( (I + \mathcal{G}_L^2)^{-\frac{1}{4}} (\mathcal{D}_L \bar{\mathbf{S}} \mathcal{D}_R^{-1} - j\tilde{q} \mathcal{G}_M) (I + \mathcal{G}_R^2)^{-\frac{1}{4}} \right), q < \tilde{q} \right\} \quad (16)$$

where  $\{\mathcal{D}_L, \mathcal{D}_R, \mathcal{G}_L, \mathcal{G}_M, \mathcal{G}_R\}$  must be chosen from sets of appropriately structured block diagonal matrices [12] and  $\tilde{q}$  is a positive scalar. The minimization problem given in Eqn. (16) is convex, and therefore the upper bound can be determined very quickly and easily [15].

## SYNTHESIS OF ROBUST GAIN MATRICES

The result of Eqns. (14) and (16) gives rise to a design algorithm for adaptive open loop control gain matrices. If the upper bound on  $\mu_\Delta(\bar{\mathbf{S}})$ , Eqn. (16), is minimized through choice of  $A$  to be less than one, then the convergence and performance robustness specifications will be achieved. The actual performance robustness must be checked after this design procedure since the performance specification is only approximate. In practice, however,  $\alpha$  can be chosen to be very large, so that the design method using the approximation produces a gain matrix satisfying the desired performance specification.

The design problem is as follows:

$$\underset{\substack{A, \mathcal{D}_L, \mathcal{D}_R, \tilde{q} \\ \mathcal{G}_L, \mathcal{G}_M, \mathcal{G}_R}}{\text{minimize}} q : q \equiv \bar{\sigma} \left( (I + \mathcal{G}_L^2)^{-\frac{1}{4}} (\mathcal{D}_L \bar{\mathbf{S}}(A) \mathcal{D}_R^{-1} - j\tilde{q} \mathcal{G}_M) (I + \mathcal{G}_R^2)^{-\frac{1}{4}} \right), \quad q < \tilde{q} \quad (17)$$

While the individual minimization with respect to  $\{\mathcal{D}_L, \mathcal{D}_R, \mathcal{G}_L, \mathcal{G}_M, \mathcal{G}_R, \tilde{q}\}$  and with respect to  $A$  are both convex, the combined minimization with respect to  $\{A, \mathcal{D}_L, \mathcal{D}_R, \mathcal{G}_L, \mathcal{G}_M, \mathcal{G}_R, \tilde{q}\}$  is not convex. Therefore, the minimization of Eqn. (17) is handled via an iteration between the two convex problems. First,  $\{\mathcal{D}_L, \mathcal{D}_R, \mathcal{G}_L, \mathcal{G}_M, \mathcal{G}_R, \tilde{q}\}$  will be fixed (starting with  $\mathcal{D}_L, \mathcal{D}_R = I$ ,  $\mathcal{G}_L, \mathcal{G}_M, \mathcal{G}_R = 0$ ) and the minimization is carried out with respect to  $A$ . Then,  $A$  is fixed and the minimization is carried out with respect to  $\{\mathcal{D}_L, \mathcal{D}_R, \mathcal{G}_L, \mathcal{G}_M, \mathcal{G}_R, \tilde{q}\}$ . This second step is just the computation of the upper bound on  $\mu_\Delta(\bar{\mathbf{S}}(A))$  given in Eqn. (16) with  $\tilde{q}$  as the resulting upper bound on  $\mu_\Delta(\bar{\mathbf{S}}(A))$ . This iterative synthesis procedure is analogous to that used in D-K iteration for  $\mu$ -synthesis [15]. The minimization is stopped when the upper bound on  $\mu_\Delta(\bar{\mathbf{S}}(A))$  is less than one.

### EXAMPLE PROBLEMS

#### *Example #1*

First, the two mass system, shown in Figure 1, is considered. While this system is very simple, its vibration behavior is analogous to that of a rotor supported in magnetic bearings. For this example, the spring between the masses has a uncertain stiffness,  $k_1$ , with a nominal value of 1. The values of the other parameters are:  $m_1 = 0.5$ ,  $m_2 = 1$ ,  $k_2 = 1$ , and  $c = 1$ . The "operating speed" of 1.2 radian/s is first considered for this example problem. This is nominally between the first and second critical speeds of the system. With a 40% decrease in stiffness, the second natural frequency approaches the operating speed. The first natural frequency is relatively insensitive to this variation in stiffness.

A gain matrix was first designed to meet the following requirements:

$$J_n \leq 1.25 J_{opt} \quad \|U_{i+1} - U_n\| \leq 0.9 \|U_i - U_n\|$$

with an uncertainty in the stiffness  $k_1$  of  $\pm 50\%$ . From these specifications, the values  $\beta = \sqrt{1.25}$  and  $\varepsilon_c = 0.9$  were used in the synthesis procedure. The free parameter  $\alpha$  was set at  $10^5$  so as to make the



$\beta \approx \kappa$  approximation accurate. The procedure was successful in synthesizing a gain matrix which meets all of the specifications.

The time response of the adaptive open loop vibration control was simulated using Eqns. (1) and (2). A comparison of the behavior of the system was conducted using the nominal system optimal gain matrix, Eqn. (5), and the gain matrix obtained by the synthesis procedure. In both cases, the convergent control algorithm was started with  $U=0$  (no open loop control forces applied). With an actual stiffness  $k_1 = 0.5$ , the quadratic performance index time history with the nominal system optimal control and with the robust control are shown in Figure 2. Both time histories have been normalized by the minimum value of the performance index  $J_{opt}$ . Note that the robust control results in very little degradation in the converged value of the performance index in comparison with the optimal value. However, the nominal system optimal gain matrix resulted in unstable adaptation.

To fully examine the performance robustness of the robust gain matrix control, 100 simulations were conducted with the actual stiffness varying from 0.5 to 1.5. Each performance index history was normalized by the optimal performance. Figure 3 shows the results of these simulations. In each case, the adaptive open loop control converges to a steady state satisfying  $J_n \leq 1.25J_{opt}$ .

#### Example #2

A more complex rotordynamic system is considered in the second example problem. Figure 4 shows a diagram of a rotor considered for a boiler feedpump application. The rotor has a length of 2.54 m, a diameter of 57 mm, and a mass of 226 kg. Two magnetic bearings are used with proportional-derivative feedback control for stabilization. The rotor also has a fluid film bearing. For the purposes of this example, the magnetic bearing feedback control as well as the fluid film bearing will be modeled as a stiffness and a damping at each bearing location as shown in the diagram (stiffness  $k_1, k_2, k_5$  and damping  $c_1, c_2, c_5$ ). Parameters  $k_3$  and  $k_4$  represent the motor's stiffness which is due to both magnetic and fluid dynamic effects. The nominal values of each of these parameters and the uncertainty in each considered in this example are shown in Table 1. The two lowest critical speeds of the nominal rotor system are 2600 and 4970 rev/min. The balancing forces are injected at bearings #1 and #3 (the magnetic bearings) so as to reduce the vibration at bearings #1 and #3 and the motor locations. These inputs and outputs are indicated in Figure 4. For this example, the operating speed of the rotor is 3000 rev/min.

A robust gain matrix was synthesized to meet the following specifications:

$$J_n \leq 1.4J_{opt} \quad \|U_{i+1} - U_n\| \leq 0.95\|U_i - U_n\|$$

Figure 5 shows the time histories of the normalized performance index for convergent control with the robust and nominal system optimal gain matrices. In these simulations, the errors in the nominal stiffnesses were:

$$\delta_1 = 0.525, \delta_2 = 0.525, \delta_3 = 0.613, \text{ and } \delta_4 = 0.088 \text{ N}/\mu\text{m.}$$

which is within the uncertainty bounds given for the parameters. The nominal system optimal gain matrix resulted in unstable adaptation for this variation. However, the robust gain matrix produced very good performance. The robustness of the synthesized gain matrix was also examined through 1000 time simulations with the system's uncertain stiffnesses chosen as uniformly distributed random numbers

within the ranges given in Table 1. The results of these simulations are shown in Figure 6. In all cases, the robust convergent control was stable and produced a steady state performance that was bounded as originally prescribed in the synthesis specification.

## CONCLUSIONS

The robustness of adaptive open loop control algorithms for suppression of synchronous vibration can be significantly improved through the application of a simple synthesis procedure. This procedure can be used to design gain matrices which have both stability and steady state performance robustness to real and complex structured uncertainties.

As the example problems demonstrate, the nominal system optimal gain matrix usually employed in adaptive open loop control can have a significant performance degradation and even instability when variations occur in the system parameters. In contrast, the performance of the robustly-synthesized gain matrix degraded significantly less from the optimal. Its worst case performance is known and was significantly better than that produced by the nominal system optimal gain matrix.

## REFERENCES

1. Haberman, H.; and Brunet, M.: The Active Magnetic Bearing Enables Optimum Damping of Flexible Rotors. ASME Paper 84-GT-117, 1984.
2. Matsumura, F.; Fujita, M.; and Okawa, K.: Modeling and Control of Magnetic Bearing Systems Achieving a Rotation around the Axis of Inertia. *Proceedings of the 2nd International Symposium on Magnetic Bearings*, Tokyo, Japan, July 12-14, 1990.
3. Burrows, C.R.; and Sahinkaya, M. N.: Vibration Control of Multi-Mode Rotor-Bearing Systems. *Proceedings of the Royal Society of London*, vol. 386, 1983, pp. 77-94.
4. Burrows, C.R.; Sahinkaya, M.N.; and Clements, S.: Active Vibration Control of Flexible Rotors: an Experimental and Theoretical Study. *Proceedings of the Royal Society of London*, vol. 422, 1989, pp. 123-146.
5. Higuchi, T.; Otsuka, M.; Mizuno, T.; and Ide, T.: Application of Periodic Learning Control with Inverse Transfer Function Compensation in Totally Active Magnetic Bearings. *Proceedings of the 2nd International Symposium on Magnetic Bearings*, Tokyo, Japan, July 12-14, 1990.
6. Larssonneur, R.; and Herzog, R.: 1994, Feedforward Compensation of Unbalance: New Results and Application Experiences. *IUTAM Symposium on the Active Control of Vibration*, Bath, UK, Sept. 1994.
7. Shafai, B.; Beale, S.; LaRocca, P.; and Cusson, E.: Magnetic Bearing Control Systems and Adaptive Forced Balancing. *IEEE Control Systems*, volume 14, no. 2, April 1994, pp. 4-13.

8. Knospe, C.; Hope, R.; Fedigan, S.; and Williams, R.: New Results in the Control of Rotor Synchronous Vibration. *Proceedings of the Fourth International Symposium on Magnetic Bearings*. vdf Hochschulverlag AG, Zurich, Switzerland, August 23-26, 1994
9. Hope, R.: *Adaptive Open Loop Control of Synchronous Rotor Vibration using Magnetic Bearings*. M.S. Thesis, University of Virginia, August 1994.
10. Knospe, C.; Hope, R.; Fedigan, S.; and Williams, R.: Experiments in the Control of Unbalance Response Using Magnetic Bearings. *Mechatronics*, vol. 5, no. 4, 1995, pp. 385-400.
11. Knospe, C.; Tamer, S.; and Fedigan, S.: Robustness of Adaptive Rotor Vibration Control to Structured Uncertainty. Submitted to *ASME Journal of Dynamic Systems, Measurement, and Control*.
12. Doyle, J.; Packard, A.; and Zhou, K.: Review of LFTs, LMIs and  $\mu$ . *Proceedings of the 30th IEEE Conference on Decision and Control*, England, 1991, pp. 1227-1232.
13. Redheffer, R.; Inequalities for a Matrix Riccati Equation. *Journal of Mathematics and Mechanics*, vol. 8, no. 3, 1959.
14. Doyle, J.: Analysis of Feedback Systems with Structured Uncertainties. *IEEE Proceedings - Part D*, vol. 133, 1982, pp. 45-56.
15. Mathworks, Inc.:  *$\mu$ -Analysis and Synthesis Toolbox*, Natick, Mass. 01760-1500, January 1994.

Table 1. Nominal Values and Uncertainties for Example #2

Parameter	Nominal Value	Uncertainty
<b>Stiffness (N/<math>\mu</math>m)</b>		
$k_1$	55	1.75
$k_2$	55	1.75
$k_3$	0	0.875
$k_4$	0	0.875
$k_5$	55	1.75
<b>Damping (Ns/mm)</b>		
$c_1$	91.3	0
$c_2$	91.3	0
$c_3$	91.3	0

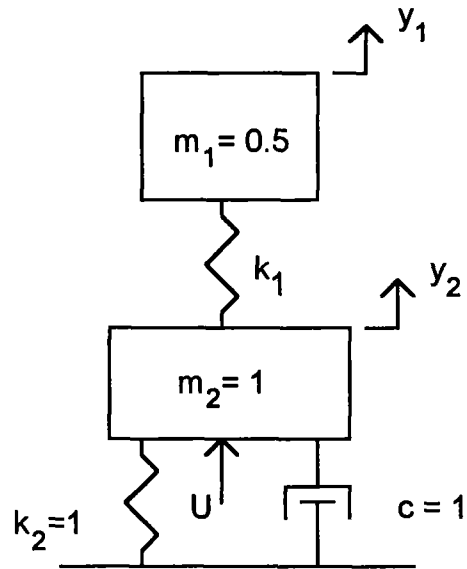

Figure 1: Simple system considered in example #1.

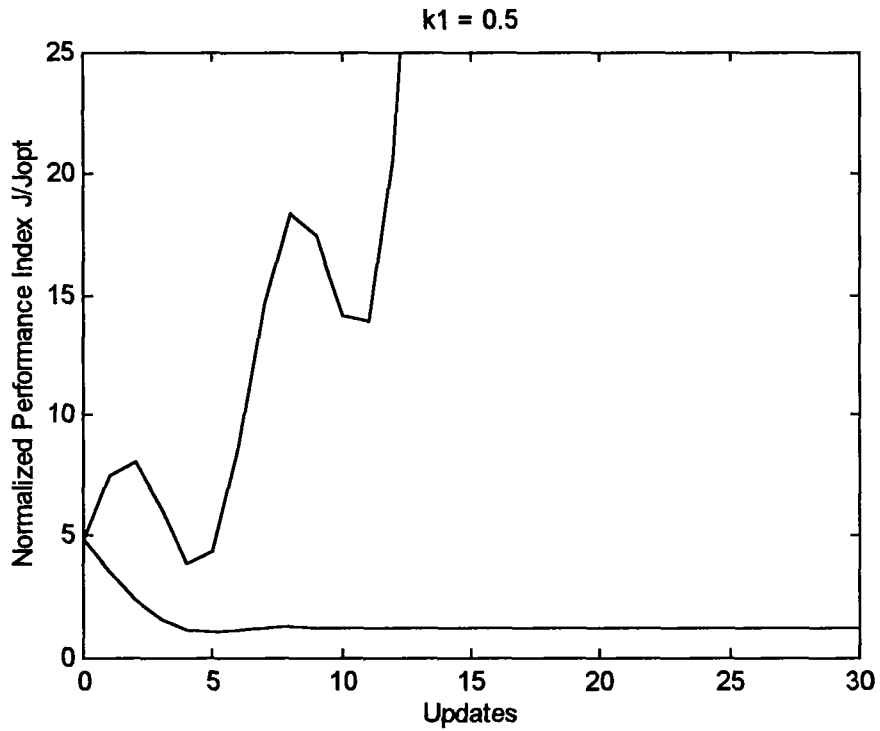

Figure 2: History of performance indices for simulation with robust and nominal system optimal gain matrices,  $k_1 = 0.5$ .

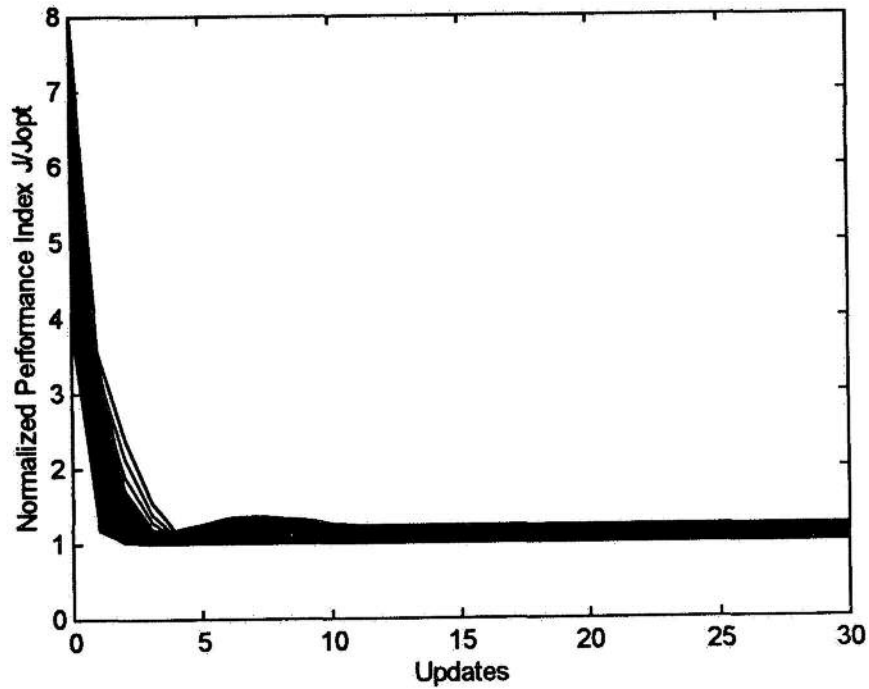

Figure 3: History of performance index for 100 simulations with robust gain matrix, stiffness varies from 0.5 to 1.5.

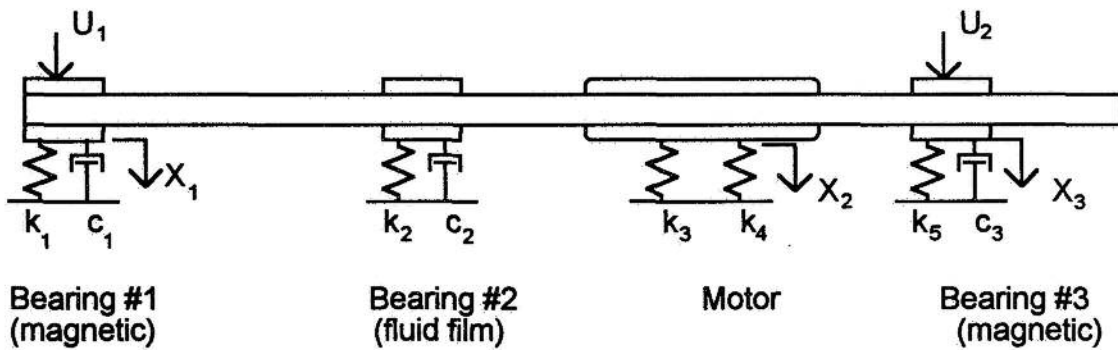

Figure 4: Rotor model considered in example #2.

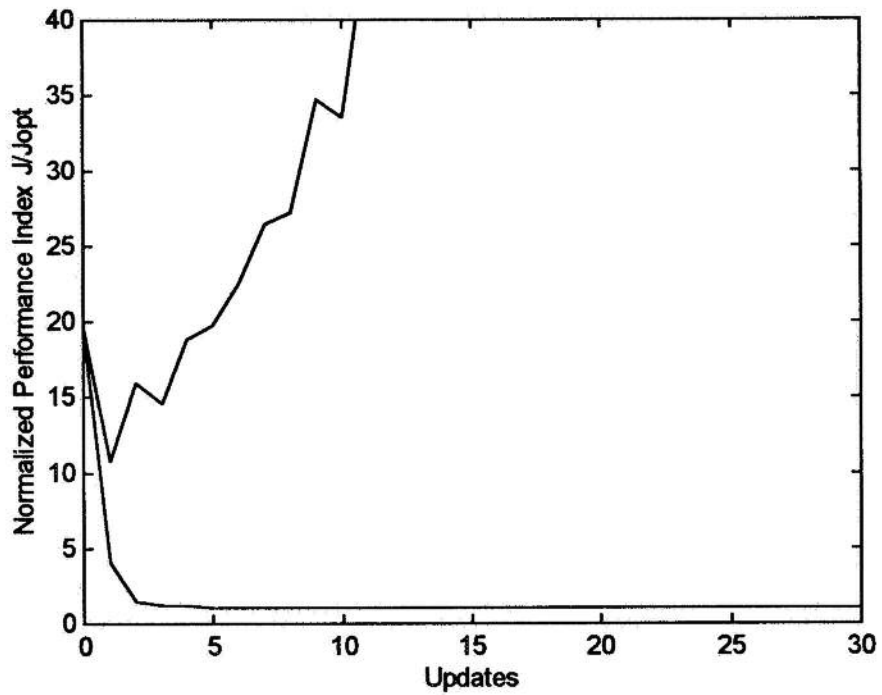

Figure 5: History of performance indices for simulation with robust and nominal system optimal gain matrices, example #2.

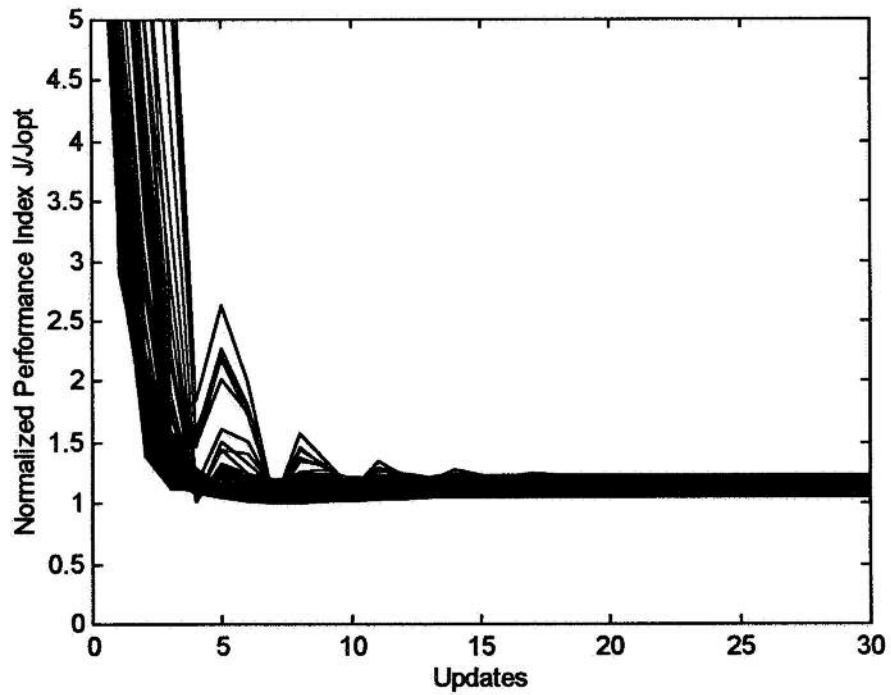

Figure 6: History of performance index for 1000 simulations with robust gain matrix, example #2, maximum  $J_n < 1.24J_{opt}$ .