

ELECTROMAGNETICALLY LEVITATED VIBRATION ISOLATION SYSTEM FOR THE MANUFACTURING PROCESS OF SILICON MONOCRYSTALS

Yoichi Kanemitsu , Katsuhide Watanabe
Ebara Research Co., Ltd., 2-1, Honfujisawa 4-chome, Fujisawa City, 251, Japan

Kenichi Yano, Takayuki Mizuno
Kajima Technical Research Institute, 19-1, Tobitakyu 2-chome, Chofu-shi, Tokyo, Japan

SUMMARY

This paper introduces a study on an Electromagnetically Levitated Vibration Isolation System (ELVIS) for isolation control of large-scale vibration.

This system features no mechanical contact between the isolation table and the installation floor, using a total of four electromagnetic actuators which generate magnetic levitation force in the vertical and horizontal directions. The configuration of the magnet for the vertical direction is designed to prevent any generation of restoring vibratory force in the horizontal direction.

The isolation system is set so that vibration control effects due to small earthquakes can be regulated to below 5(gal) versus horizontal vibration levels of the installation floor of up to 25(gal), and those in the horizontal relative displacement of up to 30 (mm) between the floor and levitated isolation table.

In particular, studies on the relative displacement between the installation floor and the levitated isolation table have been made for vibration control in the horizontal direction. In case of small-scale earthquakes (Taft wave scaled: max. 25 gal), the present system has been confirmed to achieve a vibration isolation to a level below 5 gal. The vibration transmission ratio of below 1/10 has been achieved versus continuous micro-vibration (approx. one gal) in the horizontal direction on the installation floor.

Keywords:

Vibration isolation system, Magnetic levitation, Electromagnetic actuator, Transmissibility, Vibration control, Relative feedback control, Large-scale vibration, Micro-vibration

INTRODUCTION

Recent progress in semiconductor device technology is resulting in more high precision semiconductor manufacturing and semiconductor inspection equipment. The requirements of such equipment include high precision, high performance, and high reliability.

One vital factor for satisfying these requirements is the establishment of an effective measure against vibratory effect. The use of vibration isolation systems is one such measure and such systems must feature overall prevention of vibratory effects, thus allowing uninterrupted semiconductor manufacturing processes. This means that they must prevent various vibratory effects, from those caused by small-scale earthquakes to micro-vibration effects coming from air conditioning systems, even those caused by a person moving around.

There is currently a lot of research and development being carried out on new vibration control techniques ⁽²⁾⁽³⁾. In particular, vibration in the horizontal direction causes ill effects on semiconductor manufacturing equipment in the majority of the cases.

Attempting to isolate vibration in the horizontal direction by using conventional air springs and coil springs necessitates a drop in the supportive stiffness of the equipment in order to decrease the natural frequency of the isolation system. Mounting equipment that has height may result in rocking movement.

Moreover, conventional vibration isolation mechanisms carry a problem in that they are incapable of isolating different kinds of vibration, i.e. from low-frequency large-amplitude vibrations to micro-vibration.

The present research is focused on a vibration isolation system which had none of the above problems. The isolation table on which the system is installed featured a non-contact support, i.e. the isolation table is levitated using electromagnets. This enables a complete isolation of the isolation table, in the horizontal direction, with the installation floor, thus preventing any transmission of horizontal direction vibration from the installation floor to the isolation system.

In particular, the ratio between the supportive stiffness in the horizontal direction and that in the vertical direction is made high as a measure against rocking movement.

The prototype electromagnetically levitated vibration isolating system (ELVIS) was capable of isolating any earthquake induced vibration from the installation floor of up to maximum input acceleration of 25 gal (seismic intensity of approximately 3 on the Japanese scale), including low frequency components, in the horizontal direction, and controlling such vibration to be decreased to below 1/5 of the intensity.

The following discusses the design factors of the ELVIS electromagnetic actuators and control system, and also introduces results of simulation tests and evaluation tests, the latter for which a large hydraulic shaker has been used.

NOMENCLATURE

m	Mass
$I_\alpha, I_\beta, I_\gamma$	Moment of inertia around inertia principal axis
g	Gravitational acceleration
F_x, F_y, F_z	Total controlling force of the actuators
F_{ix}, F_{iy}, F_{iz}	Controlling force of each actuator $i(i = 1 \dots 4)$
$M_\alpha, M_\beta, M_\gamma$	Total moment of the actuators
x, y, z	Isolation table displacement
α, β, γ	Isolation table rotational displacement
u, v, w	Floor displacement
ξ, η, ζ	Floor rotational displacement
K	Constant determined by the number of turns in the coil, magnetic permeability and cross-sectional area of magnetic pole magnetizing current of both facing magnets
i_p, i_n	magnetizing current of both facing magnets
h_o	Gap at equilibrium(at center of clearance)

TEST APPARATUS

Electromagnetically Levitated Vibration Isolation System

Figure 1 shows a schematic diagram of the ELVIS whose main components include the isolation table, for mounting equipment which need to be free from vibratory effects, the electromagnetic actuators, and the controller.

The electromagnetic actuators have built into them electromagnets and displacement sensors for controlling the levitation in the horizontal and vertical directions. The electromagnetic actuators are secured to the nodes of the first flexible mode of the isolation table to make the system unobservable and uncontrollable versus the first flexible mode of the table.

The isolation table is levitated without contact by the vertical control electromagnets built into the electromagnetic actuators.

As for horizontal control, the restoring force generated between the actuators in horizontal direction and the isolation table levitated by electromagnets is minimized so that there would be almost no stiffness in the horizontal direction.

The vertical direction levitating system has been made highly rigid to withstand any occurrence of rocking motion caused when mounting a piece of equipment with a height on the isolation table.

Figure 2 shows the components of the control system. They consist of vertical and horizontal control systems, and feature an analog type controller. Relative displacement in the vertical direction, between the installation floor and the isolation table, is detected

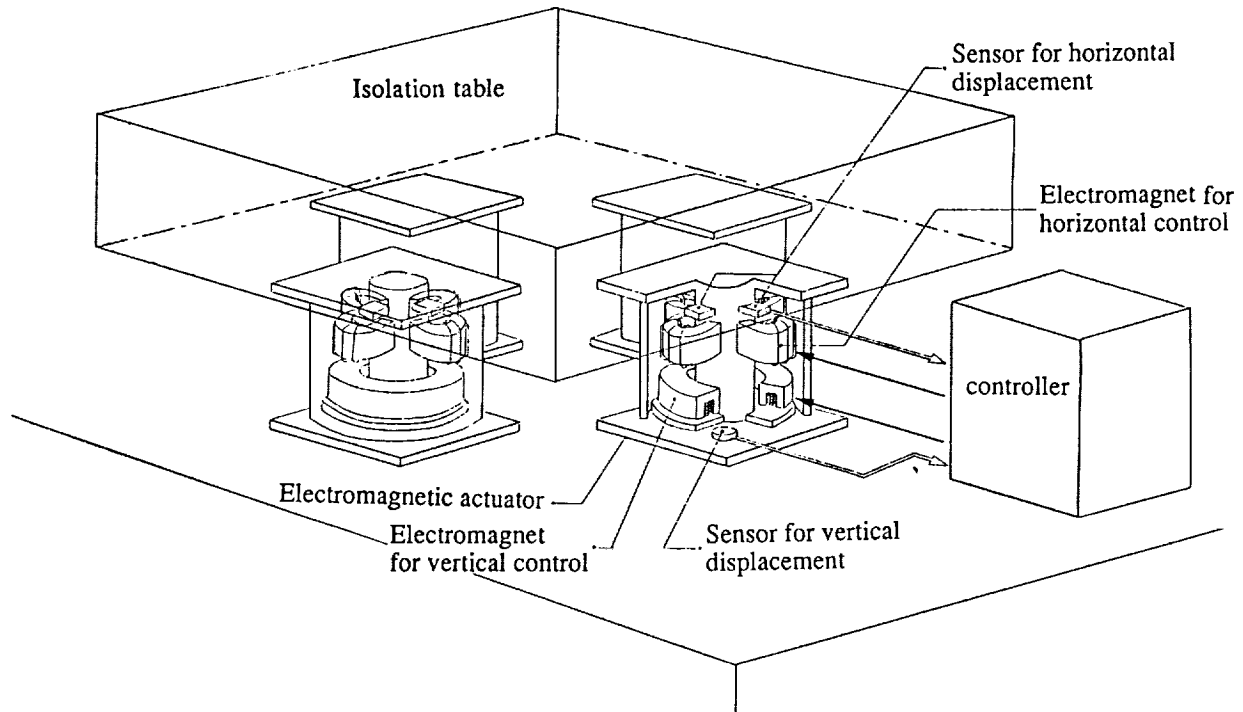

Figure 1. a schematic diagram of the ELVIS

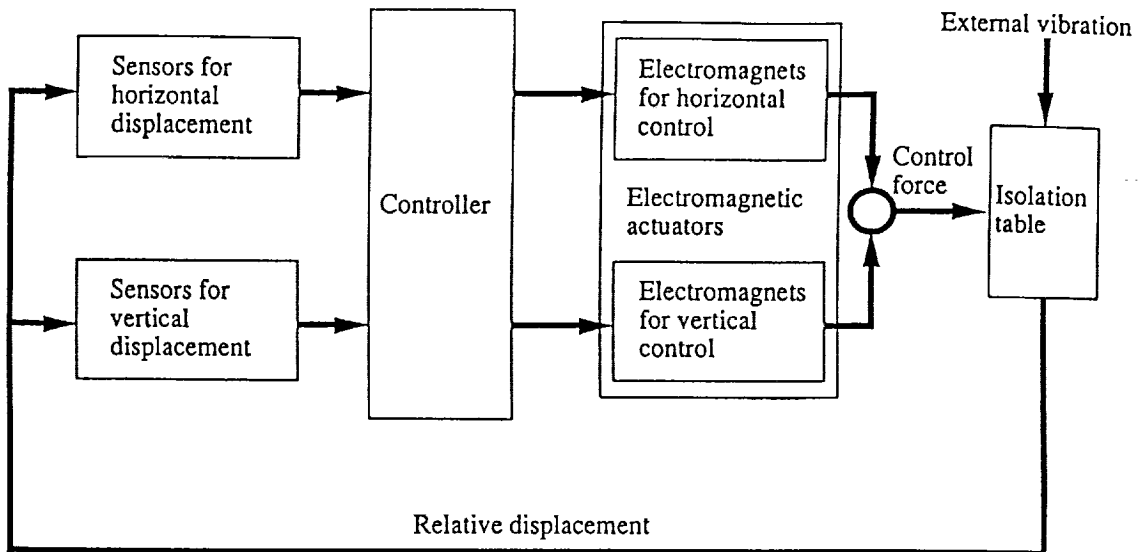

Figure 2. the components of the control system

by proximity sensors and a negative feedback of the relative displacement is used for the levitation.

Any vibratory effect caused by an earthquake in the horizontal direction is also isolated by controlling the relevant displacement to be within the allowable limit.

The specifications of the **ELVIS** are shown in table 1.

Table 1. the specifications of the **ELVIS**

Isolation performance in the horizontal direction		Earthquake	Micro-vibration
Vibration on the installation floor	Acceleration	Max. 25 gal	Max. 1 gal
	Displacement*	Max. 30 mm	—————
Transmissibility		< 1 / 5	< 1 / 10

*Relative displacement between the floor and the isolation table

Electromagnetic Actuators

The electromagnetic actuators have built-in DC electromagnets, for controlling the levitation and the motion in the vertical directions and regulating the motion in the horizontal direction, and sensors, for detecting relative displacement between the installation floor and isolation table as shown in Figure 1.

The features of each component will be discussed in the following.

(a) Features of electromagnets

The **ELVIS** uses a magnetic levitation technique by which non-contact support of an object becomes possible.

Equipment that needs to be free from vibratory effect can be mounted on an isolation table which is completely isolated from the installation floor in the horizontal direction. For this, an actuator capable of keeping the stiffness ratio between the horizontal and vertical directions at $1 : 10^3 \sim 10^4$ has been developed.

A conventional vibration isolation system using air spring or rubber spring has relatively larger stiffness ratio than the isolation system using the magnetic levitation.

The actuators are designed so that the stiffness in the horizontal direction can be kept smaller than that in the vertical direction, allowing the input vibration amplitude of up to ± 30 mm in the horizontal direction.

Figure 3 (a) shows the attractive electromagnetic force (analytical and measured) of a vertical direction controlling electromagnet versus the magnetizing current, while Figure 3(b) shows the measured restoring force of the vertical electromagnet versus displacement in the horizontal direction from a neutral point. The abscissa represents the displacement in horizontal direction between center positions of the levitation magnet pole and the levitated disk.

The attractive force shown in Figure 3 (a) is of a case where the magnetizing current is increased under a condition of constant gap (which is equal with the control gap during levitation). The abscissae represents the nondimensional magnetizing current, necessary for non-contact support of the levitated body and normalized by the magnetizing current for levitating the isolation table , and the ordinate represents the nondimensional attractive force which is generated by the magnetizing current and is normalized by a gravity force of the levitated table (design values: 5kN).

Figure 3 (a) shows that the electromagnet is capable of generating a magnetic force that is approximately three times the desired value for the levitation until magnetic saturation is reached.

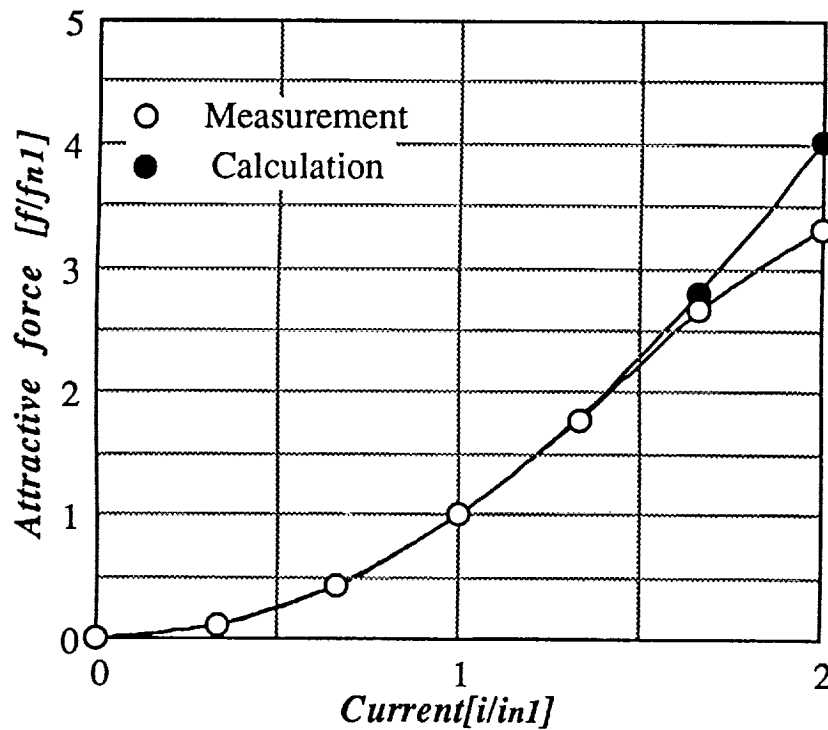
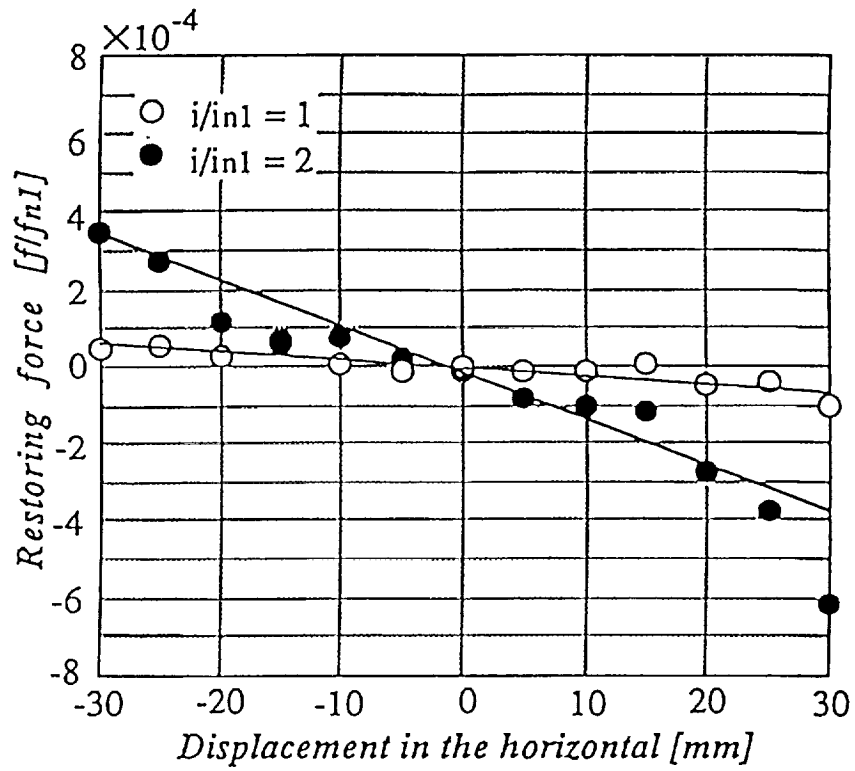

Figure 3 (a) attractive force of electromagnet for vertical control

In contrast, Figure 3(b) shows that the restoring force in the horizontal direction, generated by magnetic flux leakage of the vertical direction controlling electromagnet, is shown to be four notches below the attractive force. The inclination of this force is the passive spring constant taking effect in the horizontal direction, indicating that there is almost no horizontal force generated by the vertical control electromagnet .

The horizontal electromagnets have been designed to face each other as single-bodied electromagnets, capable of generating an attractive force within the gap of ± 30 mm, and controlling vibration in horizontal direction.

FEM have been employed to calculate the attractive force between the magnet and the attracted yoke precisely.



(b) restoring force of electromagnet in horizontal direction
 Figure 3. attractive and restoring force of electromagnet

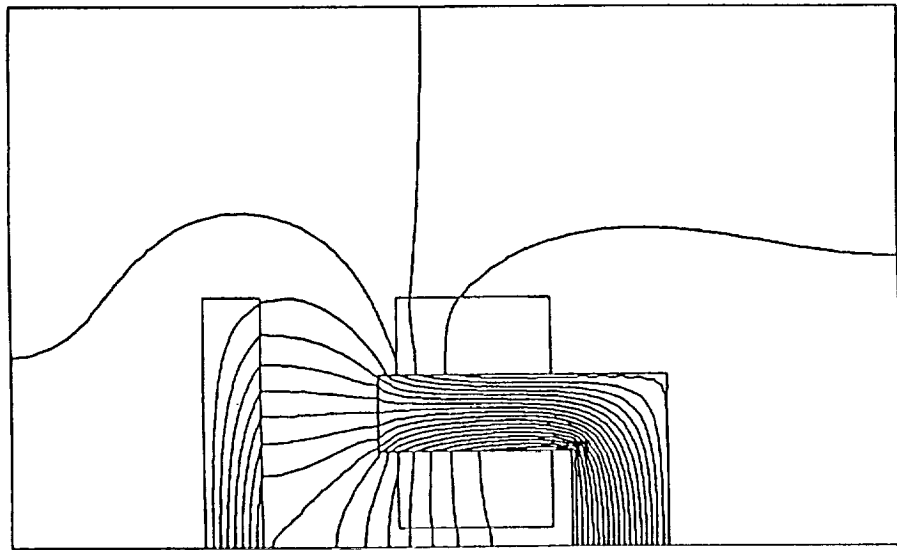

Figure 4. an example of FEM analysis results on the magnetic field of the horizontal control electromagnet with a gap of 30 mm

Figure 4 shows an example of FEM analysis results on the magnetic field of the horizontal control electromagnet with a gap of 30 mm. We can see from the figure that here is a lot of magnetic flux leakage due to the great gap between them.

Figure 5 shows calculated and measured results of the nondimensional attractive force with a gap of 30 mm. The calculated results correspond with the measured results.

(b) Features of large-scale displacement sensors

Prototypes of large-scale displacement induction type sensors, which use the bottom surface of the levitated disk for vertical control, have been developed. These sensors are used for detecting the large horizontal relative displacement between the installation floor and the isolation table, thus enabling control of horizontal vibration.

Figure 6 shows the characteristics of these sensors for horizontal displacement. The specified linearity (error below 6.0%) and specified sensitivity (5.0V/30 mm) have been achieved within the measurement range which is the design specification of ± 30 mm.

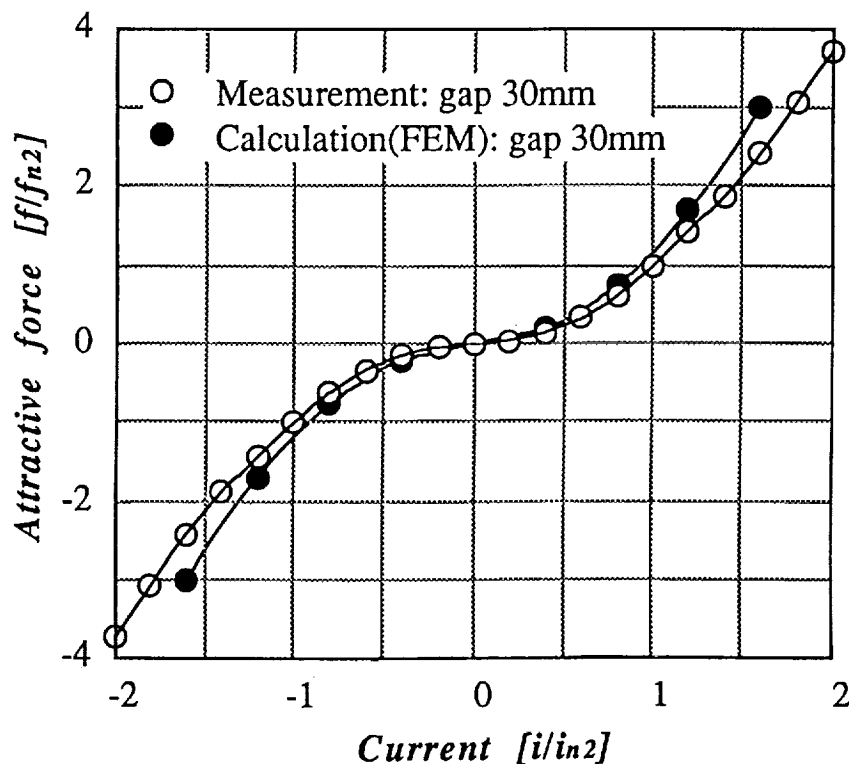

Figure 5. calculated and measured results of the nondimensional attractive force with a gap of 30 mm

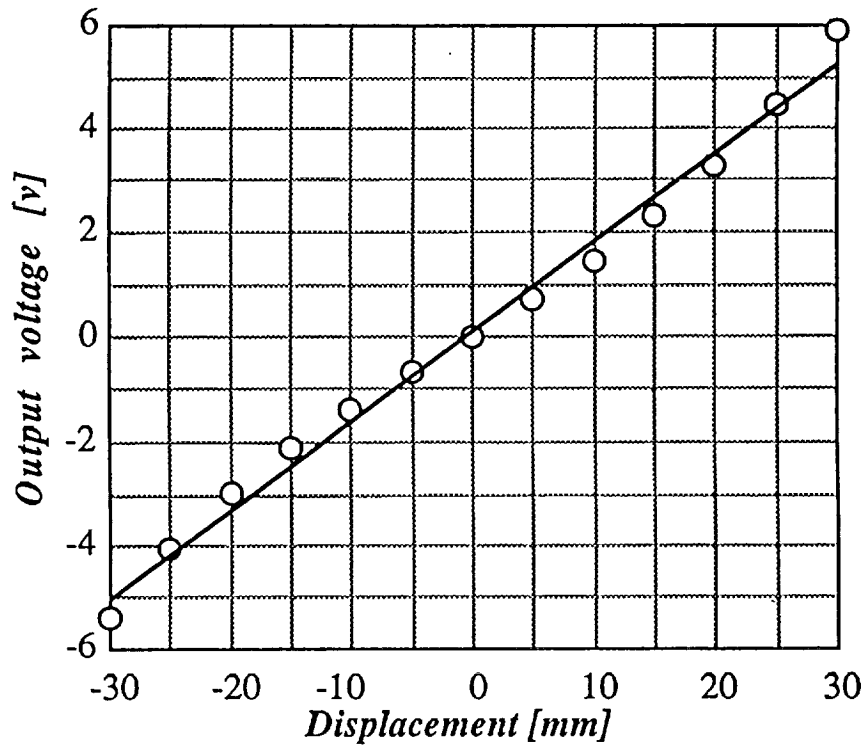

Figure 6. the characteristic of sensor for horizontal displacement

CONTROL SYSTEM

Model of the isolation system

Figure 7 shows a model of the ELVIS wherein the isolation table is supported by four electromagnetic actuators. Each actuator's supportive direction is aligned with the coordinate axes and it is assumed that the actuator's points of application are on the x - y surfaces and the coordinates of axes are matched with principal axes of inertia and products of inertial are removed.

The equations of motion of the isolation system, indicated below in (1) ... (6), are written with each freedom of movement expressed independently and any cross-coupled effects are removed.

They represent rigid vibration modes of the table whereby flexible vibration modes of the isolation table are neglected.

$$m\ddot{x} = F_x = (F_{1x} + F_{2x} + F_{3x} + F_{4x}) \quad (1)$$

$$m\ddot{y} = F_y = (F_{1y} + F_{2y} + F_{3y} + F_{4y}) \quad (2)$$

$$m\ddot{z} = F_z = (F_{1z} + F_{2z} + F_{3z} + F_{4z}) \quad (3)$$

$$I_\alpha \ddot{\alpha} = M_\alpha = l(F_{3z} - F_{1z}) \quad (4)$$

$$I_\beta \ddot{\beta} = M_\beta = l(F_{2z} - F_{4z}) \quad (5)$$

$$I_\gamma \ddot{\gamma} = M_\gamma = l(F_{1x} - F_{2x} - F_{3x} + F_{4x}) \quad (6)$$

From the above equations, the isolation system is expressed in 3-D with six degrees of freedom.

However, we decided to design and assess the system with the target of isolating vibration in the horizontal direction (x and y directions) under a 2-D condition.

As mentioned before, non-contact support of the isolation table makes it possible to remove almost all stiffness in the horizontal direction. It is therefore possible to regulate the acceleration of the isolation table without any transmission of vibration coming from the installation floor.

However, the relative displacement between the installation floor and the isolation table

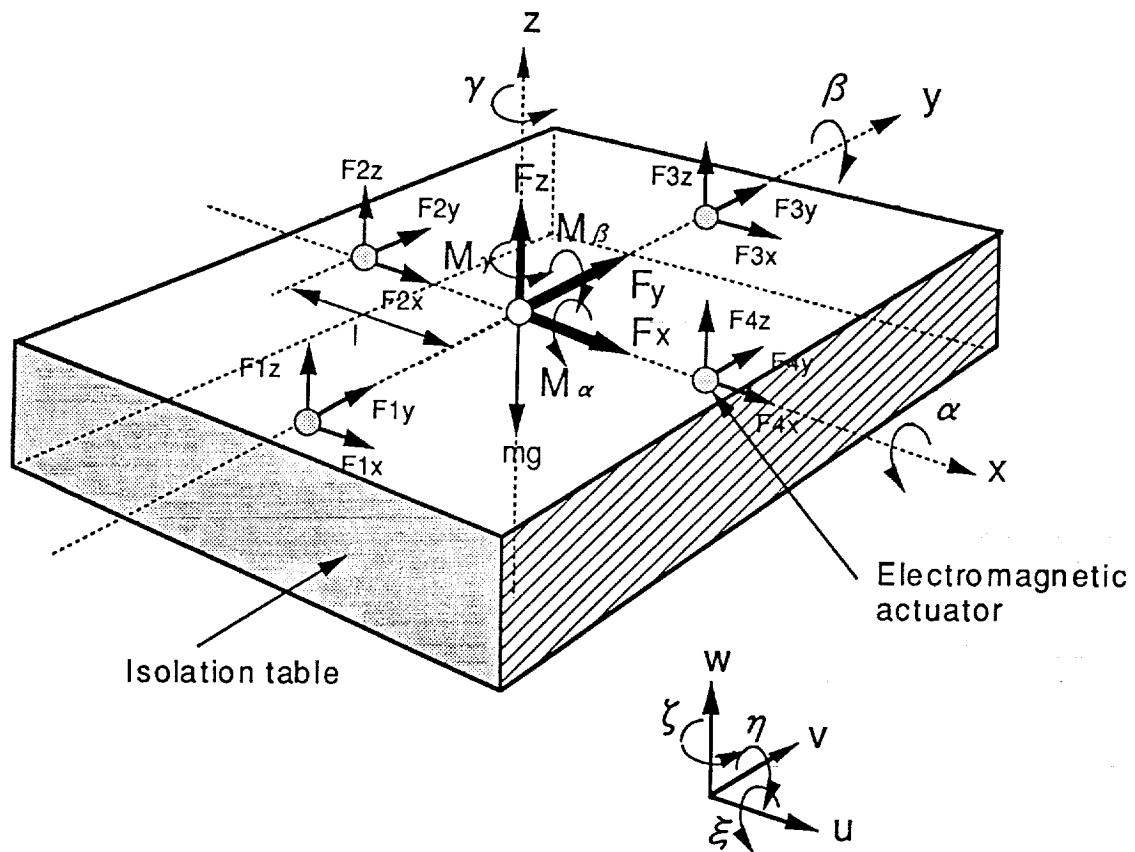

Figure 7. model of the ELVIS wherein the isolation table is supported by four electromagnetic actuators

becomes greater and there is a risk of contact between the electromagnets and members of attracted yokes, i.e. depending on the intensity of vibration (displacement amount) at the installation floor.

Furthermore, if there is unevenness on the surface of the installation floor, the isolation table may shift to the lower side as there is no stiffness. For these reasons, it becomes necessary to augment appropriate stiffness and damping in the horizontal direction.

A horizontal isolation system, featuring the use of relative displacement feedback, has been designed to cope with the situation. The horizontal isolation system (translation motion) will be focused hereon.

Model of the electromagnets

The attractive force of the horizontal control electromagnets carries a non-linear characteristic as clearly defined in Figure 5. The following equation (7) can be used for calculating this attractive force.

$$f = K\left(\frac{i}{h}\right)^2 = K\left(\frac{i_p}{h_0 - x + u}\right)^2 - \left(\frac{i_n}{h_0 + x - u}\right)^2 \quad (7)$$

Normally, the linear relationship between the electric current and attractive force is plotted after passing a bias magnetizing current into the electromagnet. However, it was difficult to do this due to the big gap (30 mm ~ 60 mm).

Applying the bias current also results in an imbalance stiffness (negative stiffness), necessitating an increased feedback amount for stabilization. In such case, the stiffness becomes increased but the isolation performance deteriorates.

In our case, output signals from a phase compensation circuit flow into the amplifier via a square root circuit for enabling a simplified assimilation whereby a linear relation is made consisting of amplifier input signals and the attractive force.

Amplifier input signals and the output current are proportional. Accordingly, the following equation can be used to express the magnetic attractive force versus the output signals from the phase compensation circuit (input signals of the root circuit).

$$f = K_c v_c \quad (8)$$

where v_c is the output signals from the phase compensation circuit.

Results of actual measurement indicated that $K_c = 0.5$. However, the value of K_c changes with fluctuations in the gap.

Horizontal Controller

The following discusses the design of the isolation system for horizontal control by negative feedback of the relative displacement. The equations of motion for the translation motion are as indicated in the following:

$$m\ddot{x} = \sum_{i=1}^4 F_{ix} \quad (9)$$

$$m\ddot{y} = \sum_{i=1}^4 F_{iy} \quad (10)$$

where

$$F = F_{ix} = F_{jy} (i = 1 \dots 4, j = 1 \dots 4)$$

and Laplace transforming equations (8) and (9), we get

$$ms^2 X(s) = 4F(s) = 4K_c v_c(s) \quad (11)$$

Considering x_r as the relative displacement between displacement u of the installation floor and displacement x of the isolation table, and feeding back this relative displacement value together with the relative velocity by controller $G(s)$ indicated in equation (11), equation (11) is transformed into equation (12). The transfer function of the vibration transmissibility of this isolation system becomes as indicated in equation (14) via equation (13).

$$G(s) = -(K_0 + K_1 s) \quad (12)$$

$$ms^2 X(s) = 4K_c G(s) X_r(s) = -4K_c (K_0 + K_1 s) (X(s) - U(s)) \quad (13)$$

$$\frac{X(s)}{U(s)} = \frac{4K_c K_1 s + 4K_c K_0}{ms^2 + 4K_c K_1 s + 4K_c K_0} \quad (14)$$

Parameters K_0 and K_1 of controller $G(s)$ are set to be as the isolation system's natural frequency of 0.3 Hz with the damping ratio of 0.2. The value of K_c used is that at the location of equilibrium (gap of 30 mm).

Figure 8 shows the transmissibility of the isolation system, wherein measured and calculated transfer functions in both the horizontal and vertical directions are shown for comparison.

We can see from the figure that the bandwidth of the isolation system in vertical direction is up to 35Hz and the natural frequency in horizontal direction is 0.3Hz.

NUMERICAL SIMULATIONS

Numerical simulations have been carried out to confirm whether the designed feedback system is capable of obtaining an isolation performance which satisfied the specifications.

Taft waves, including low frequency components of below 1 Hz, and micro-vibration (White Noise ≤ 1.0 gal) are input into the mathematical model of the isolation system.

Although Taft waves are typical seismic waves for assessing antiseismic performance, they constitute high vibration waveforms. For this reason, they had to be scaled down to below Max. 25 gal, the design specification. Figure 9 shows results of numerical simulation on isolation performance versus seismic and micro-vibration. Figure 9(a) shows input acceleration waveform of Taft's wave to the installation floor in horizontal direction. Figure 9(b) shows absolute acceleration waveform on the levitation table in horizontal direction.

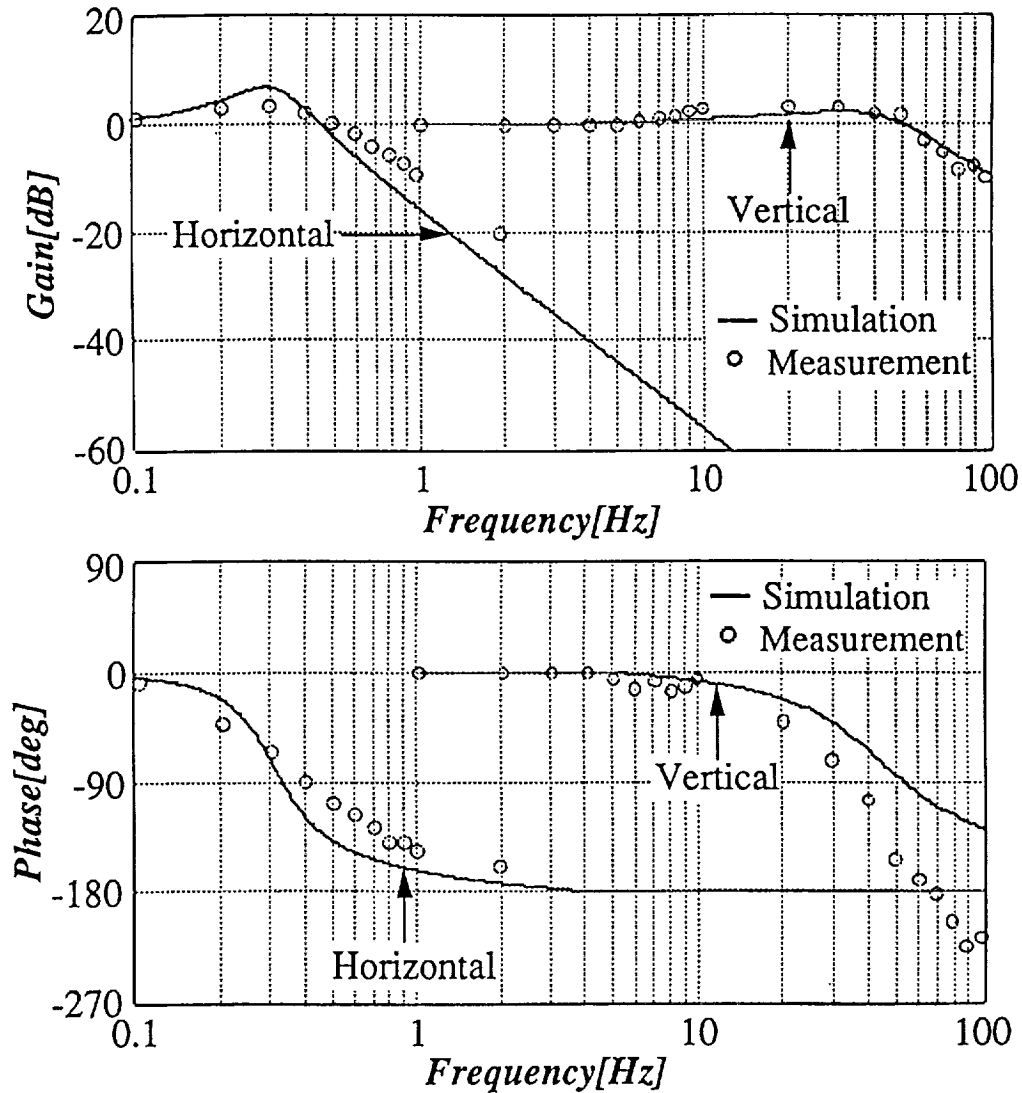
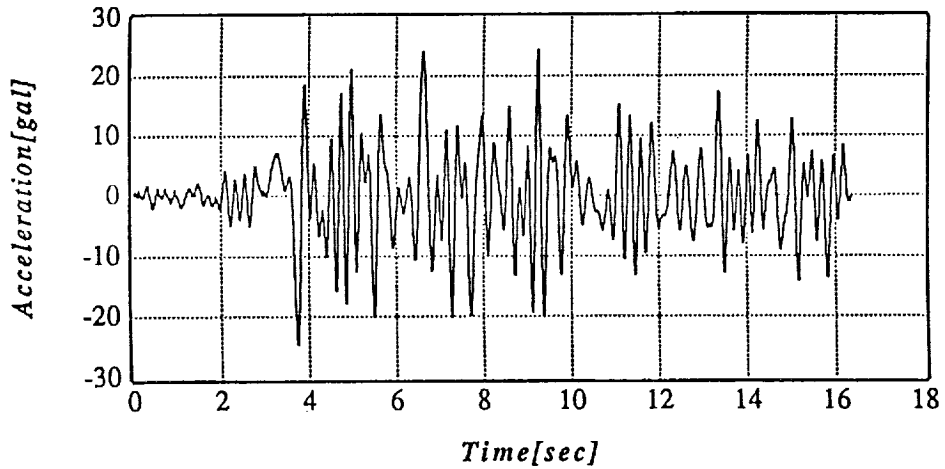

Figure 8. measured and calculated transfer functions of the isolation system in both the horizontal and vertical directions

Figure 9(c) shows relative displacement waveform between the installation floor and the levitation table in horizontal direction. Figure 9(d) shows absolute acceleration waveform of micro-vibration to the installation floor in horizontal direction, whose maximum amplitude is up to 1.0 gal. Figure 9(e) shows absolute acceleration waveform of micro-vibration on the table in horizontal direction.

It is acknowledged from the simulation results of simulations that for the seismic vibration, isolation is achieved to below 1/5, while for micro-vibration, to below 1/100.



(a) input acceleration waveform of Taft's wave to the installation floor in horizontal direction

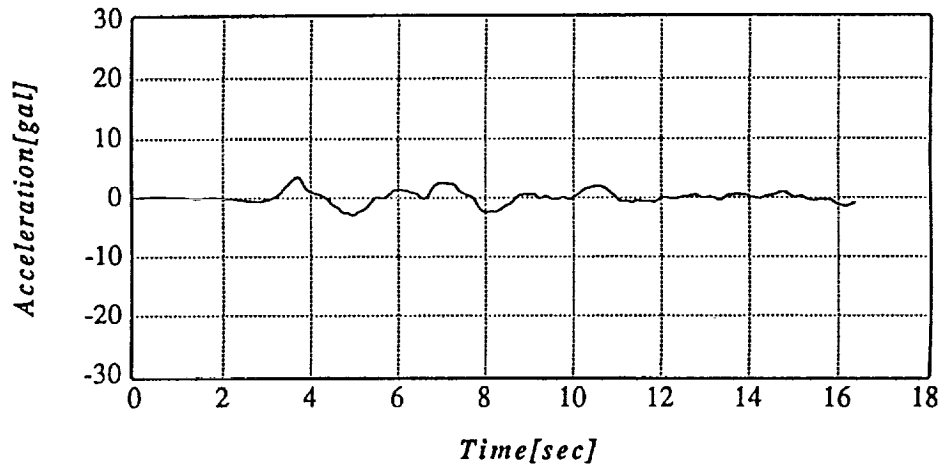

(b) absolute acceleration waveform on the levitation table in horizontal direction

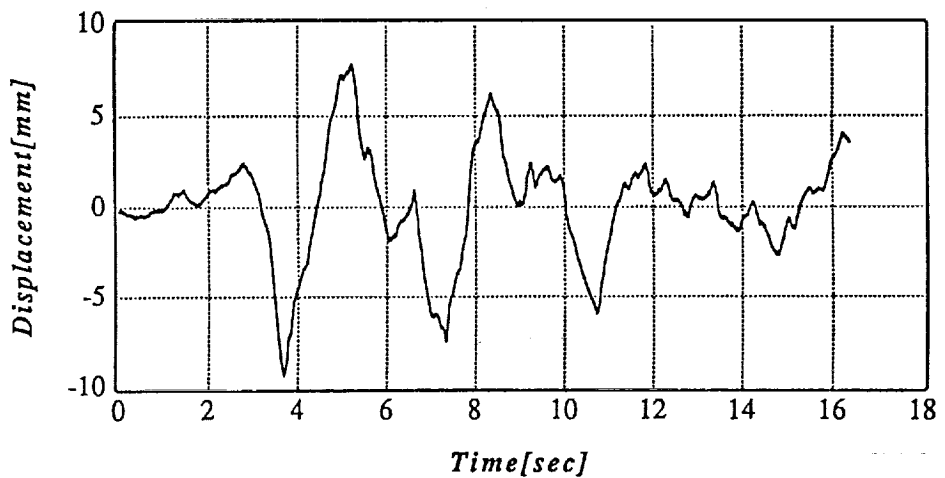

(c) relative displacement waveform between the installation floor and the levitation table in horizontal direction

Figure 9. results of numerical simulation on isolation performance versus seismic and micro-vibration 5mm

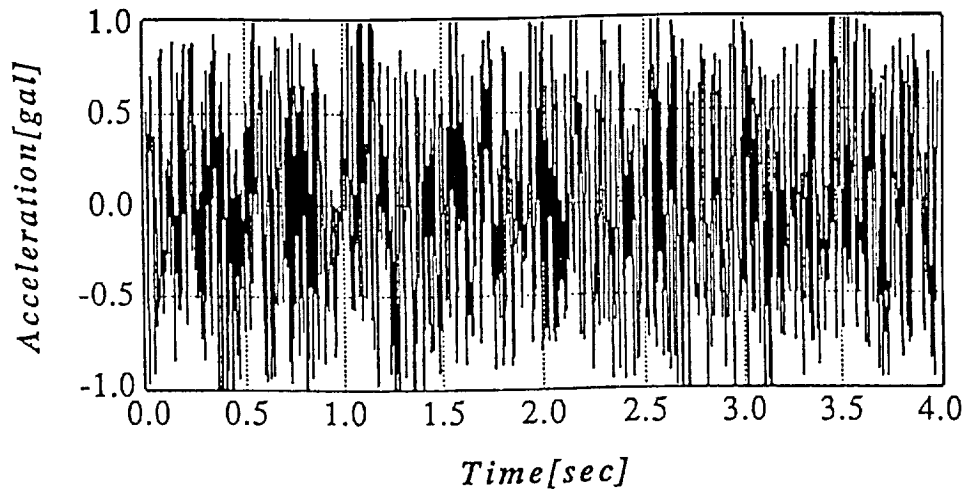

(d) absolute acceleration waveform of micro-vibration to the installation floor in horizontal direction whose maximum amplitude is up to 1.0 gal

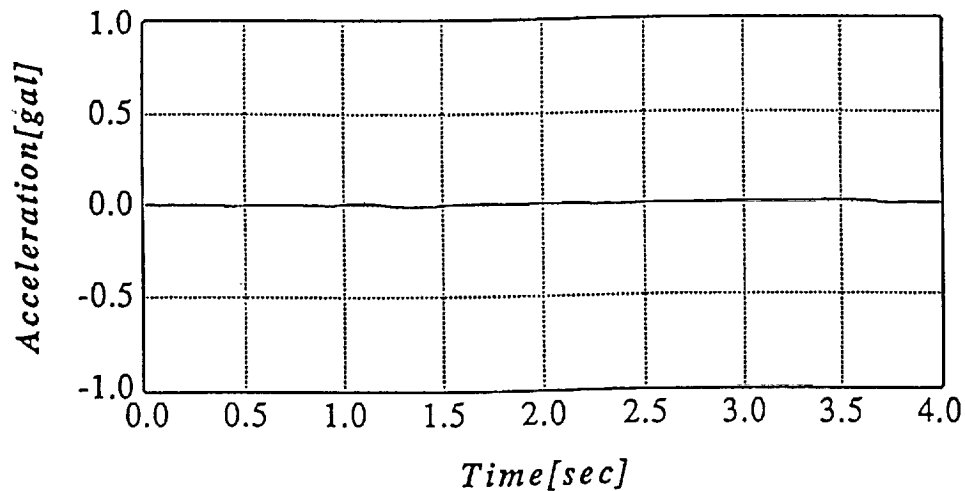

(e) shows absolute acceleration waveform of micro-vibration on the table in horizontal direction

Figure 9. results of numerical simulation on isolation performance versus seismic and micro-vibration

SHAKER TESTS

The **ELVIS** is mounted on a shaking table and vibration tests have been carried out by the input of seismic waves. Figure 10 shows a general view of the **ELVIS** mounted on the shaking table, while Figure 11 shows results of the isolation tests by shaker. Figure 11(a) shows input acceleration waveform of Taft's wave to the installation floor in horizontal direction. Figure 11(b) shows absolute acceleration waveform on the levitation table in

horizontal direction. Figure 11(c) shows relative displacement waveform between the installation floor and the levitation table in horizontal direction. Figure 11(d) shows absolute acceleration waveform of micro-vibration to the installation floor in horizontal direction, whose maximum amplitude is up to 1.0 gal. Figure 11(e) shows absolute acceleration waveform of micro-vibration on the table in horizontal direction.

The shaker test using Taft waves (Max. 25 gal) indicated that an isolation to below 1/5 has been achieved, matching the result of the relevant simulation result. As for the isolation of micro-vibrations, isolation has been achieved to below 1/10. This is nowhere near the same by the simulation result (below 1/100), a drop in isolation performance probably due to sensor noise.

The transmissibility for the horizontal direction is identical to those measured in the numerical simulations as seen in figure 8.

The characteristics for the vertical direction indicate a natural frequency of 35 Hz and a damping ratio of 0.5.

Shaker tests have been also carried out whereby shifts of 45 degrees from the X- and Y-axes are made, the results of which are identical to the former shaker tests. It is thus confirmed that the isolation system has no effect on the transmissibility in the horizontal direction, by excitation direction, indicating that there is not any problem as for the direction of input vibration.

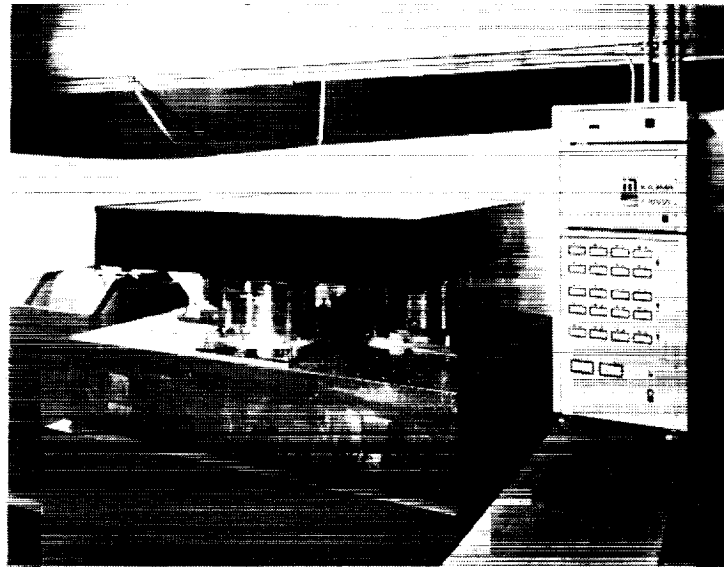
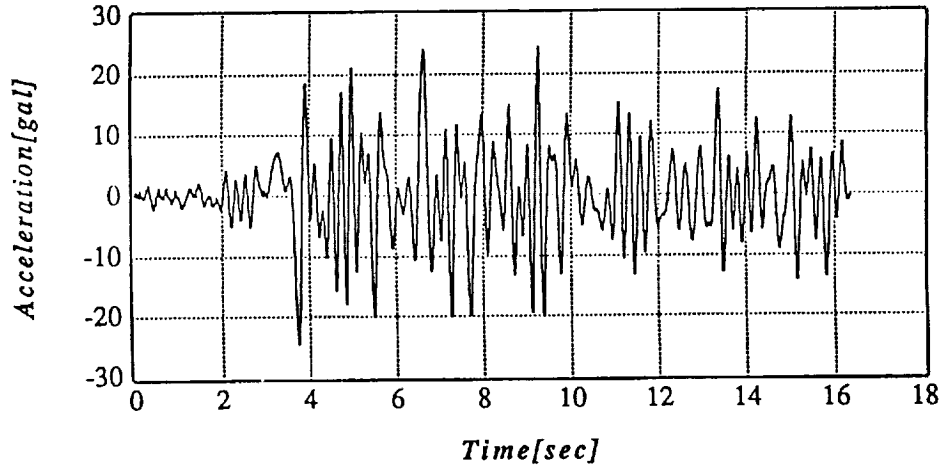
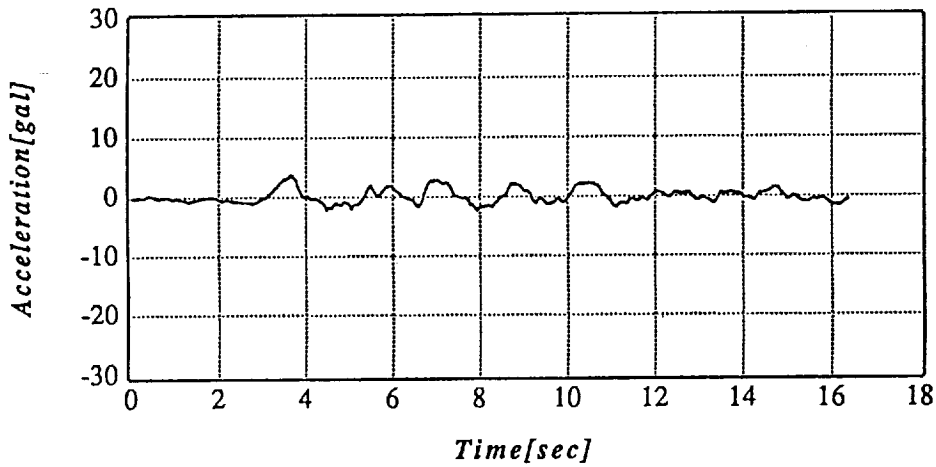

Figure 10. general view of the ELVIS mounted on the shaking table



(a) input acceleration waveform of Taft's wave to the installation floor in horizontal direction



(b) absolute acceleration waveform on the levitation table in horizontal direction

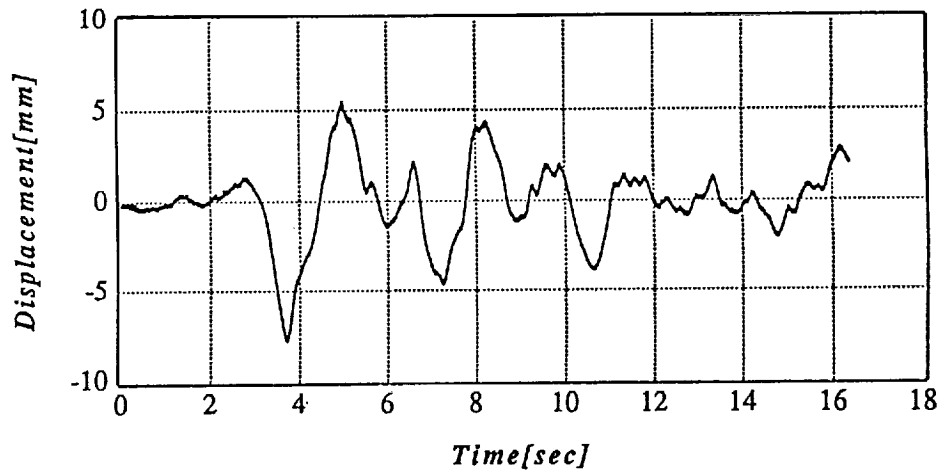

(c) relative displacement waveform between the installation floor and the levitation table in horizontal direction

Figure 11. results of the isolation tests by shaker

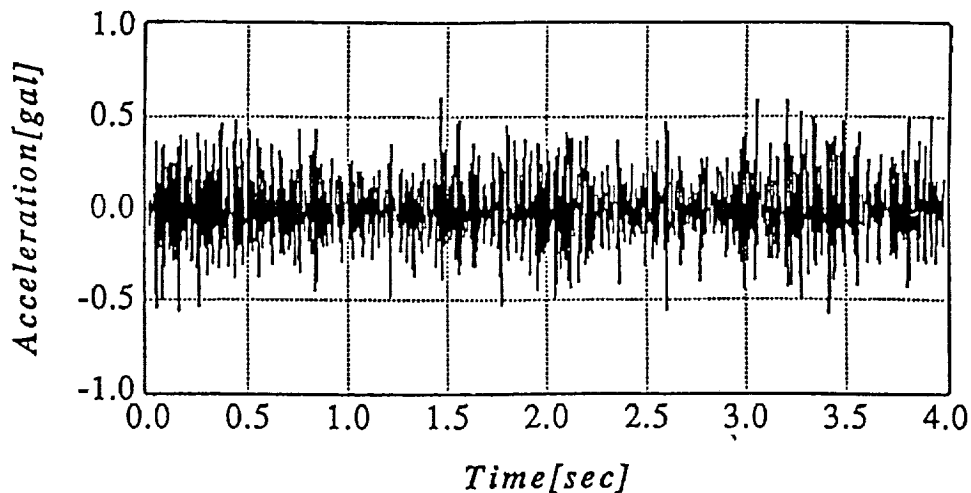

(d) absolute acceleration waveform of micro-vibration to the installation floor in horizontal direction, whose maximum amplitude is up to 1.0 gal

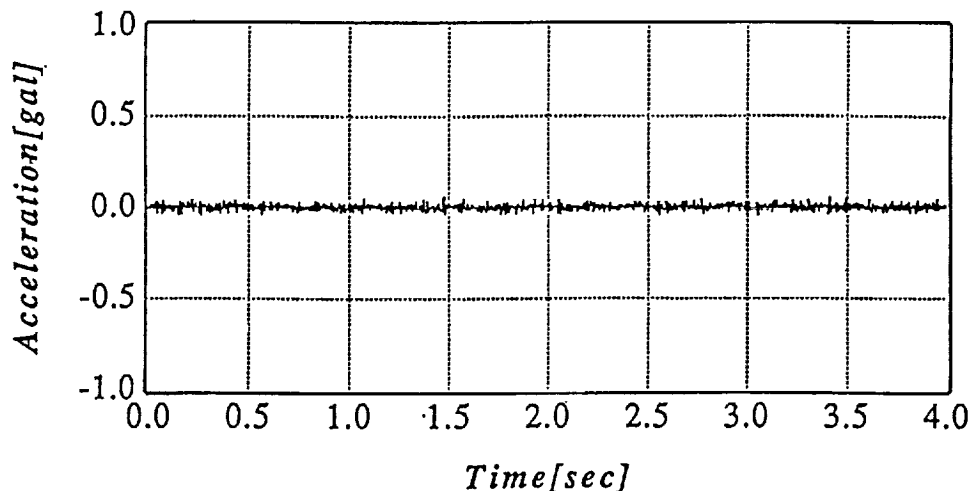

(e) absolute acceleration waveform of micro-vibration on the table in horizontal direction

Figure 11. results of the isolation tests by shaker

CONCLUSIONS

The two-dimensional horizontal direction prototype of electromagnetically levitated vibration isolation system, featuring a magnetic levitation technique for vibration isolation, has been tested to confirm its vibration isolation performance. The following are conclusions obtained from the results.

1. It is confirmed that magnetically levitating the isolation table for mounting equipment that need to be free from vibratory effects results in omitting stiffness in the horizontal direction and isolating vibration that is otherwise transmitted from the installation floor.

2. It is confirmed through shaker tests that an isolation to below 5 gal is achieved using Taft waves of maximum amplitude 25 gal, including components which are below 1 Hz (transmissibility is below 1/5) . As for the isolation of micro-vibrations of approximately 1 gal, isolation is achieved to below 0.1 gal (transmission ratio is below 1/10).
3. The degree of stiffness for the horizontal and vertical directions can be set independently. A horizontal direction two-dimensional isolation system, featuring no occurrence of rocking, can be established by controlling the stiffness for the vertical direction to be approximately 10,000-fold of that for the horizontal direction.

REFERENCES

- (1) TokiTa, Morimura: Vibration Control Handbook(Fuji Technosystem)
- (2) Takahashi et al: A Study on Active Vibration Control System using a Linear Motor, J. of Struct. Const. Eng. Architectural Institute of Japan , No. 412, June 1990
- (3) Fujita: Research on Earthquake Resistant Structures , Takashi Fujita Laboratory Report, No. 2 , Institute of Industrial Science , University of Tokyo