

## FUZZY SELF-LEARNING CONTROL FOR MAGNETIC SERVO SYSTEM

J.H. Tarn L.T. Kuo K.Y. Juang C.E. Lin

Institute of Aeronautics and Astronautics  
National Cheng Kung University  
Tainan, Taiwan10/1/83  
P. 8

## ABSTRACT

It is known that an effective control system is the key condition for successful implementation of high-performance magnetic servo systems. Major issues to design such control systems are nonlinearity; unmodelled dynamics, such as secondary effects for copper resistance, stray fields and saturation; and that disturbance rejection for the load effect reacts directly on the servo system without transmission elements. One typical approach to design control systems under these conditions is a special type of nonlinear feedback called gain scheduling. It accommodates linear regulators whose parameters are changed as a function of operating conditions in a preprogrammed way.

In this paper, an on-line learning fuzzy control strategy is proposed. To inherit the wealth of linear control design, the relations between linear feedback and fuzzy logic controllers have been established. The exercise of engineering axioms of linear control design is thus transformed into tuning of appropriate fuzzy parameters. Furthermore, fuzzy logic control brings the domain of candidate control laws from linear into nonlinear, and brings new prospects into design of the local controllers.

On the other hand, a self-learning scheme is utilized to automatically tune the fuzzy rule base. It is based on network learning infra-structure; statistical approximation to assign credit; animal learning method to update the reinforcement map with a fast learning rate and temporal difference predictive scheme to optimize the control laws. Different from supervised and statistical unsupervised learning schemes, the proposed method learns on-line from past experience and information from the process and forms a rule base of an FLC system from randomly assigned initial control rules.

## INTRODUCTION

Interest in research on large-gap magnetic suspension systems began in the early 1960's. The principal goal was the elimination of aerodynamic support interference in wind tunnel testing. In early 1970's the interest extended to small-gap systems. The first system developed was the Annular Momentum Control Device (AMCD) with applications to the stabilization and control of spacecraft [1]. This research was continued with the Annular Suspension and Pointing System (ASPS) which provides orientation, mechanical isolation, and fine pointing of space experiments [2,3]. For decades, Magnetic suspension technologies (MST) have demonstrated their capabilities in many fields, from

industrial compressors, high-speed milling and grinding spindles, magnetically levitated trains, and control wheel suspension for spacecraft to rocket propulsion turbomachinery. Important features of the magnetic suspension and actuator systems are:

(1) Versatility of the Electromagnetic Forces

The physical force of a magnetic circuit to a high-permeable armature is called the Maxwell-force. Contrary to this commonly used force, the reaction force of a conductor carrying a current in a magnetic field is called the Lorentz-force. Successful integration of these physical effects and the constructed electromagnetic subsystem can be utilized as a rotary motor, linear actuator, radial bearing, thrust bearing, etc.

(2) Molecule-size Resolution

One problem of electric-motors is the ripple of motion at low-speed operating regions due to the finite pole effect. The rotor always rests at the finite circumference positions which have the minimum magnetic flux (potential energy). Thus there are inherited limitations for resolution of control. The non-pole magnetic field provided by a coil, on the other hand, sets no resolution limitation. The resolution limit, in turn, is set by sensors, instrumentation and control strategies. Magnetic suspension systems provide a promising approach for achieving positioning with nanometer resolution.

In this paper, a linear positioning system with a linear force actuator and magnetic levitation is to be designed. By locating a permanently magnetized rod inside a current-carrying solenoid, the axial force is achieved by boundary effect of magnet poles and utilized to power the linear motion, while the force for levitation is provided by magnetic bearing and governed by maximum linkage principle. With the levitation in a radial direction, there is no friction between the rod and solenoid. The demand of high speed motion can hence be achieved. Under the proposed arrangement, the axial force act on the rod is a smooth function of rod position, so the system can provide nanometer-resolution linear positioning to the molecule size. It is known that an effective control system is the key condition for successful implementation of high-performance magnetic levitated positioning systems. Major issues for design of such control systems are:

(1) Nonlinearity

By assuming that the complete energy of the magnetic field is concentrated within the air gap. The basic mathematical models of active magnetic bearing are obtained from Maxwell's laws. The input-output relations are highly nonlinear despite the variables defined.

(2) Unmodelled Dynamics

Secondary effects such as copper resistance, stray fields and saturation are neglected.

(3) Disturbance Rejection

Because the load effect reacts directly on the servo system without transmission elements, the capability of "disturbance rejection" is also required.

With the above considerations, a fuzzy logic controller with PD type rule-base is utilized. A self-learning scheme for a fuzzy logic controller is used to form a proper rule-base for FLC. The characteristics of this self-learning FLC are as follows:

- (1) It is based on the adaptive neuron-like element concepts, statistical approximation, animal learning and temporal difference predictive method [4].
- (2) The scheme can get a quick learning rate by using the animal learning method.
- (3) It is different from the supervised learning. Without knowing the system dynamics, this learn-

- ing scheme can learn from past experience to form a rule-base for fuzzy logic controllers.
- (4) It is different from the statistical unsupervised learning scheme. Conventionally, the statistical unsupervised learning scheme learns from the fail experiences, so it belongs to off-line learning. In contrast, this scheme is an on-line learning scheme by getting information from the control process.
  - (5) As the rule-base formed, a fuzzy logic controller can work independently without a learning mechanism.

Effectiveness of the control systems are illustrated by numerical simulation results.

## SYSTEM DYNAMICS

### System Configuration

Consider a magnetic servo system shown in Figure 1, where  $r_1$  is 1.1 cm,  $r_2$  is 1.0 cm and the length of the rod is 1.0 cm; the length of the solenoid is 10 cm. The current supplied to the solenoid will generate a magnetic field around the rod and result in a linear motion. To achieve the function of levitation, the current in the solenoid must be kept in the direction that can maintain the stability of radial motion. Under such condition, the axial motion is unstable, i.e., the magnetic force in axial direction tends to push the rod away from the center of the solenoid. Hence the spring is required to supply the force in the opposite direction. Also, the spring must be precompressed to avoid an uncontrollable equilibrium point. The additional magnetic bearing system is used to keep the moving part balanced in axial direction. With a biased current fed to the solenoid, the magnetic force in radial direction is utilized to suspend the moving part, while, with the controlled current, the axial motion is governed by the force caused by a non-uniform magnetic field in the boundary.

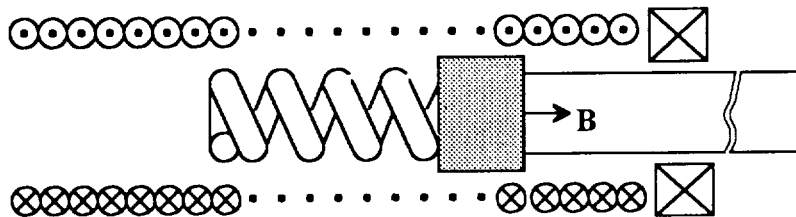

Figure 1 The configuration of a magnetic levitated linear positioning system

## Dynamics of the System

The magnetic force induced by the current in the solenoid is a nonlinear function of the position. The dynamic equation of the servo system can be expressed as

$$\begin{aligned}\dot{x}_1 &= x_2 \\ \dot{x}_2 &= -\frac{1}{m}[K_1 \cdot (x_1 + x_p) + K_2(x_1) \cdot (i + i_b)]\end{aligned}$$

where

- $x_1, x_2$  = position and velocity of the rod respectively, cm, cm/sec
- $K_1$  = stiffness of the spring, N/cm
- $K_2(x)$  = current controlled stiffness of solenoid-rod configuration, N/A
- $x_p$  = pre-compressed length of the spring, cm
- $i_b$  = biased current for levitation, A
- $i$  = controlled current, A
- $m$  = mass of the moving part includes the load, kg

$K_2(x_1)$  is the input gain of the system, which is the nonlinear function of rod position described in Figure 2. In short, the system can be simplified as the configuration in Figure 3, where  $K_2$  is a nonlinear current controlled stiffness spring.

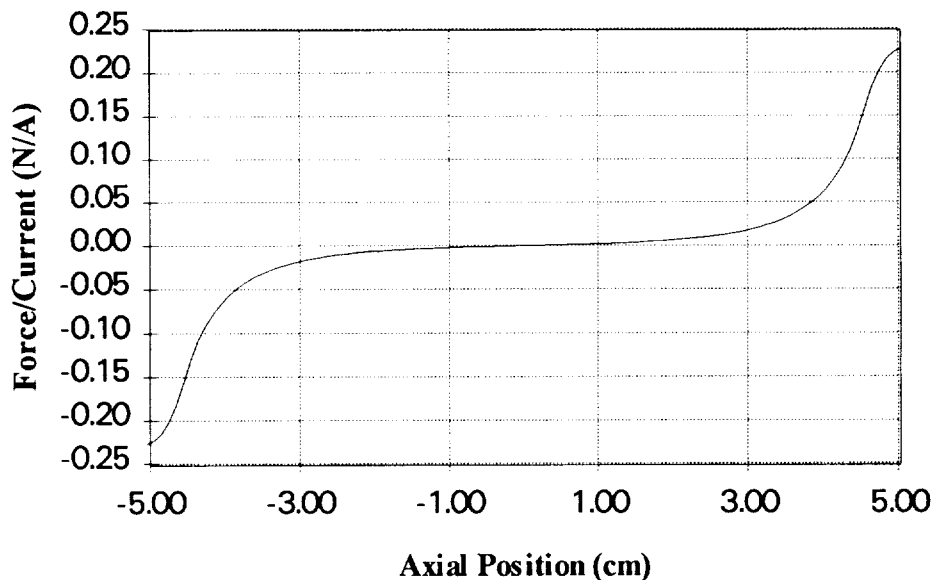

Figure 2 Force-position relation in axial motion.

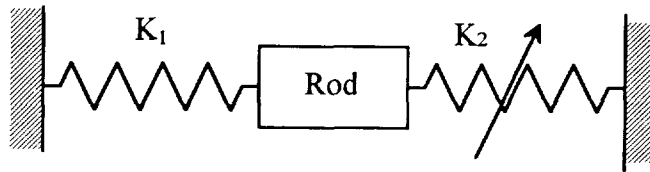

Figure 3 Simplified model of axial motion.

## SELF-LEARNING FUZZY LOGIC CONTROLLER

### Architecture of Self-Learning FLC

In a Fuzzy Logic Controller designing process, we use a self-learning scheme to form a proper control rule-base automatically from past control actions and experiences. After the rule-base has been formed, an FLC can work independently to control the magnetic suspension system.

The architecture of the self-learning FLC is shown in Figure 4. To achieve the on-line learning purpose, a performance evaluator (called Critic element) is needed to determine the system performance and to react to the environment changes at the end of each learning period. This unit produces an external reinforcement signal,  $R$ , to provide information for the learning mechanism to learn from. While receiving the reinforcement, the external information is evaluated and an internal reinforcement,  $\hat{r}$ , is sent to the next unit by the adaptive critic unit (ACU). This signal helps to judge the necessary changes of the control rules. The associative search unit (ASU) searches a proper control force location in the rule space for each control rule in the rule-base of FLC according to the internal reinforcement and system status. After the rules are changed, this rule-base is held over next learning period to show its control effects and to accumulate its experiences. At the end of the next learning period, an external reinforcement,  $R$ , is evaluated again and the learning process is continued recurrently. It is shown that all firing strengths of control rules are sent to both ACU and ASU to assist these mechanisms to accumulate past experience.

More distinctly, our learning process introduced above is implemented following the steps below:

- (1) At time instance  $k$ , the firing strength  $\mu_i$ , the control action  $u_i$  in each rule, and the system output  $y(k)$  are available.
- (2) Critic element determines external reinforcement,  $R$
- (3) ACU evaluates internal reinforcement,  $\hat{r}$
- (4) ASU updates control rules,  $u_i$
- (5) FLC calculates the current action,  $f$ , by fuzzy inference
- (6) Send the action to system, repeat steps (4) and (5) over this learning period
- (7) Repeat step (1) at next learning period

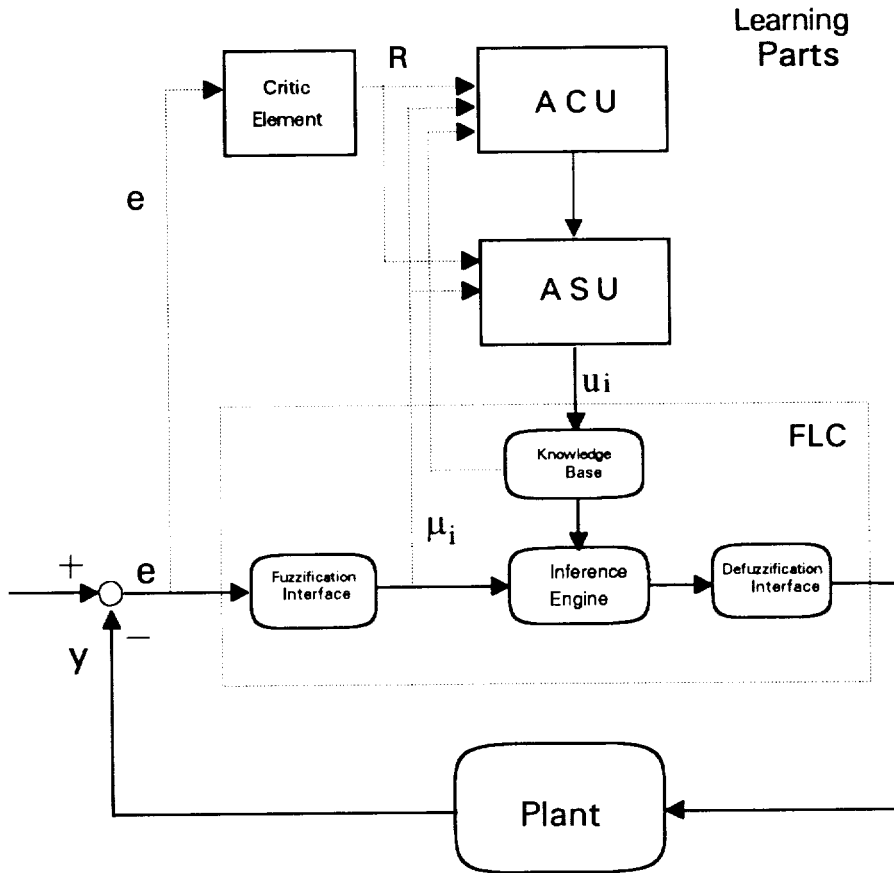

Fig 4 : The Architecture of The Self-learning Fuzzy Logic Controller

### A Self-Learning Scheme for FLC

The learning algorithms are described as follows :

\* The critic element :

$$R = -\frac{1}{\max(|a|, |b|)} \left( \frac{1}{N} \sum_{k=1}^N |E(kT)| \right)$$

\* The adaptive critic unit ( ACU ) :

$$\begin{aligned}
 p(t) &= \sum_{i=1}^n v_i(t) \mu_i(t) & ; & & 0 \leq \gamma \leq 1 \\
 \hat{r} &= \gamma p(t) - p(t-1) & ; & & 0 < \beta \leq 1 \\
 v_i(t+1) &= v_i(t) + \beta R \hat{\mu}_i(t) & ; & & 0 \leq \lambda < 1 \\
 \hat{\mu}_i(t) &= \lambda \hat{\mu}_i(t-1) + (1 - \lambda) \mu_i(t) & ; & & 
 \end{aligned}$$

\* The associative search unit ( ASU ) :

$$\begin{aligned} u_i &= FL \times \tanh(Kw_i) \\ e_i(t) &= \delta e_i(t-1) + (1-\delta)\mu_i(t)u_i(t) \quad , \quad 0 \leq \delta < 1 \\ w_i(t+1) &= w_i(t) + \alpha \text{sign}(E) |e_i(t)(R + \hat{r})| \end{aligned}$$

where  $R$  is the external reinforcement signal;  $N$  is the sampling numbers in a learning period;  $T$  is the sampling period; the working range of error is  $[a,b]$ ;  $u_i$  is the control force of  $i$ -th rule;  $\mu_i$  is the firing strength of  $i$ -th rule;  $e_i$  is called eligibility of the  $i$ -th rule;  $\hat{r}$  is the internal reinforcement evaluated by ACE;  $\alpha$  is the learning rate and  $\delta$  is the forgetting factor.

### Simulation Result

In the simulation, the fuzzy logic controller reads the input terms "error", "change in error" and concludes the output term "change in control force". The term "error" is defined in  $[-3,3]$  and is partitioned into 9 equal-space intervals; the membership of each interval is of isosceles triangle form. The term "change in error" is the measurement of the velocity, which is defined in  $[-50,50]$  and is partitioned into 7 equal-space intervals. The geometry of its membership is also an isosceles triangle. The 63 rules are initialized with random number and trained with algorithms described in the previous section for 500 training process from initial condition 4.0 to setpoint 2.5. The simulation result is given as Figure 5. In this figure, the results of the trained controller applied to different operating points are also demonstrated.

### CONCLUSION

From the results, the effectiveness of the learning scheme and the robustness of fuzzy logic controllers are shown. It works well, though the input gain of the system varies with the operating point significantly. Such capability is achieved by the nonlinearity of the fuzzy logic controller.

out responses with different set point and initial condition

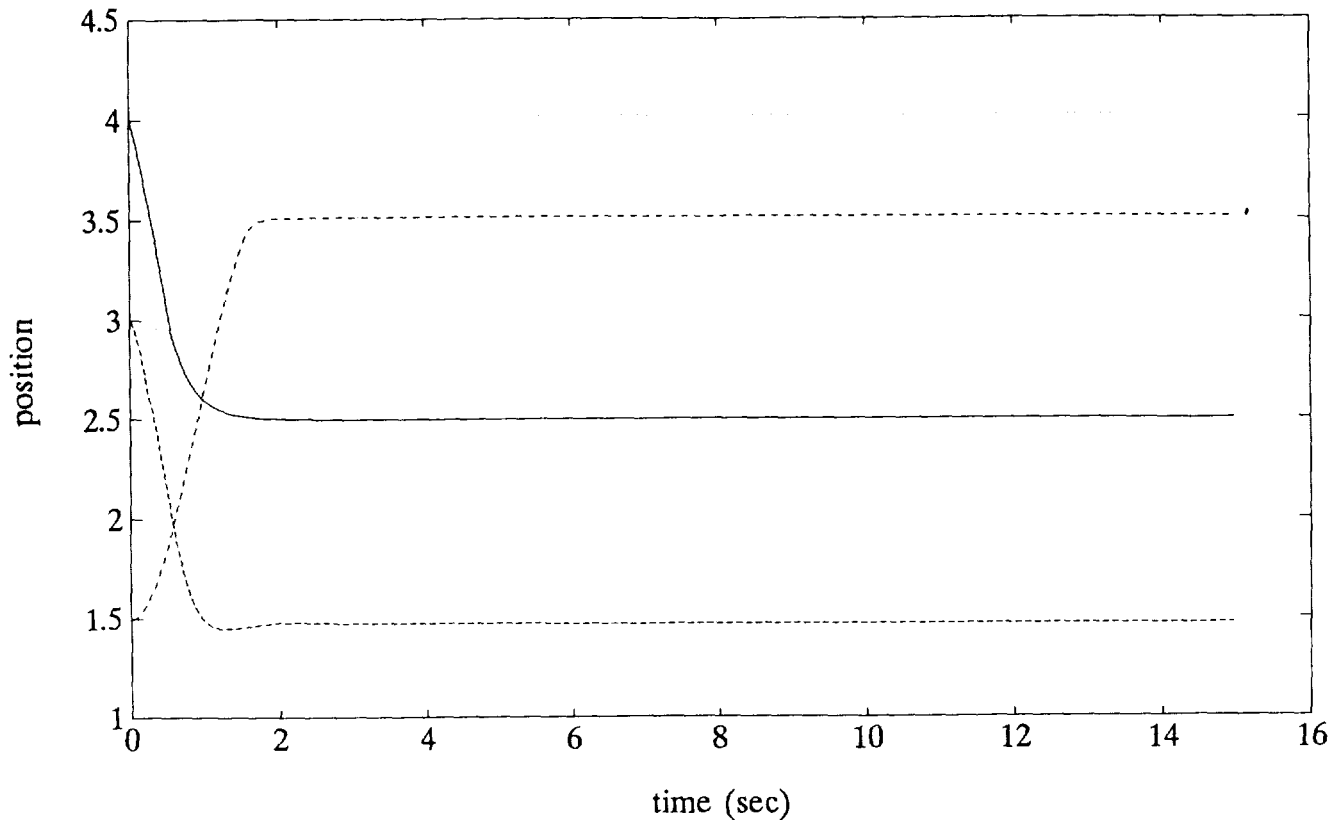

Figure 5 Simulation results with fuzzy logic controller.

#### REFERENCE

- [1] Anderson, Willard W. and Groom, Nelson J., "The Annular Momentum Control Device (AMCD) and Potential Applications," NASA TN D-7866, 1975.
- [2] Anderson, Willard W. and Joshi, Suresh M., "The Annular Suspension and Pointing (ASP) System for Space Experiments and Predicted Pointing Accuracies," NASA TR R-448, 1975.
- [3] Anderson, Willard W. ; Groom, Nelson J. and Woolley, Charles T., "The Annular Suspension and Pointing System," Journal of Guidance and Control, Vol. 2, No. 5, 1979, pp. 367-373.
- [4] R.S.Sutton, "Learning to Predict by the Methods of Temporal Difference", Machine Learning 3, pp. 9-44.