

# Backup Bearing Modelling for Turbo Machines with High Axial and Radial Loads

Dr. Jan J. Janse van Rensburg<sup>a</sup>, Christian Vanek<sup>b</sup>, Prof. Dr.-Ing. Frank Worlitz<sup>b</sup>

<sup>a</sup> School of Mechanical and Nuclear Engineering, North-West University, Potchefstroom 2520, South-Africa, Jan.JanseVanRensburg@nwu.ac.za

<sup>b</sup> Hochschule Zittau/Görlitz IPM, Theodor-Körner-Allee 16, 02763 Zittau, Germany, cvanek@hszg.de; f.worlitz@hszg.de

**Abstract**— The use of active magnetic bearings (AMBs) in turbo machines is an active research topic and the implementation in industrial applications is becoming commonplace. This is especially true when investigating the backup bearings (BBs) for high speed rotors with high axial and radial loads. In AMB supported turbo machines there usually are high axial process forces present, and should the axial AMB (AAMB) fail, these forces need to be supported by the axial backup bearings (ABBs). In order to design appropriate BBs the movement of the rotor and the associated forces produced during a rotor delevitation event (RDE) is of critical importance. These forces should be determined using a rotor delevitation model that includes the forces on all the backup bearings and the effect that these forces have on the rotor stability. This paper presents a short overview of various types of ABBs in the literature and the associated models for these BBs. The second part of the paper presents a model for a novel BB currently under construction at the IPM, and how this model is integrated into the rotor delevitation model BBSim [1]. The third part of the paper presents some results obtained using the proposed ABB model. The results investigate the effect that the radial distance where contact occurs and the axial force present on the rotor has on the RDE severity based on the  $V_{val}$  values.

## I. BACKGROUND ON ABBs

The process forces in turbo machines cause high forces in the axial direction. During AMB failure these forces on the ABB has a destabilizing effect in the radial direction. This destabilizing force is dependent on the contact between the ABB and the rotor. Schmied and Pradetto identified the phenomena of forward whirling in [2]. Wilkes et al presented the consequences axial contact has on the shaft movement during a rotor drop in the backup bearings [3]. These authors show that a sub-critical frequency can develop destructive whirling if the rotor is in contact with the ABB during a RDE. In machines with axial forces present on the BBs it is important to stabilize the whirl motions in order to achieve safe rotor delevitation. The effect of these axial forces and contact with the ABB on the behavior of the rotor during a RDE should be known and is important in the design of an intrinsically safe machine.

## A. Layout of ABBs in the literature

Machines with high axial loads are usually designed to have a vertically orientated rotor. In vertical machines with a combined axial/radial BB the gravity force is used to stabilize the rotor [4-6]. A vertical machine was developed for the high temperature reactor; the BB for this machine is shown in Fig. 1. The tapered carbon clutch helps to stabilize the rotor in the radial direction [5].

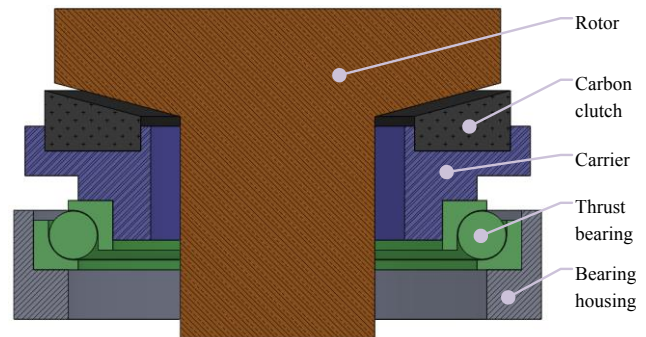

Figure 1. Schematic of the design of an ABB for vertical machines [5].

Since there is no stabilization effect in horizontal machines the layout as shown in Fig. 1 would also be advantages for use in these machines. The most commonly utilized layout for ABBs is a combined axial-radial BB [5, 7-9]. When using a combined axial-radial BB the influence of the radial stiffness and damping has on the axial forces experienced by the BB should be investigated. Some other machines use brass rings that is integrated into the axial AMB as the ABBs [10] These types of ABBs are usually implemented when the axial loads are relatively low and the wear of these rings can be managed. It is important to note that for radial BBs, rolling element bearings are commonly used in vertical machines and plain bearings is more commonly used in horizontal machines.

## B. ABB Modeling

In 2002, Orth and Nordmann presented a tool to calculate the non-linear dynamics of AMBs [11]. The tool includes a model for the ABBs. Sun et al presented a detailed rolling element bearing model for the radial BBs and a point mass

model for the ABB [9]. The schematic of the dynamic ABB model is shown in Fig. 2

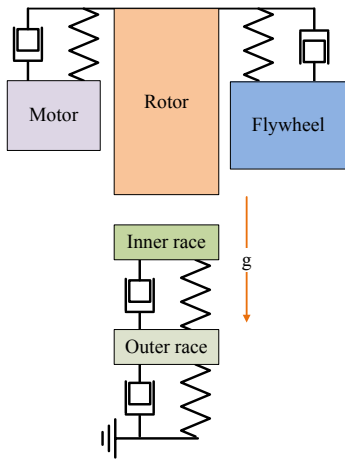

Figure 2. Schematic of the dynamic model of an ABB developed by Sun et al. [9]

## II. AXIAL BACKUP BEARING (ABB)

### A. Mechanical design of the ABB

The University of applied sciences Zittau/Görlitz is developing a test bed for AMBs and BBs the MFLP [12]. The goal of this test bed is research in the field of AMB applications in extreme conditions. Plain BBs were chosen for this test bed since these are commonly used in extreme conditions to prevent contamination of the process fluid, especially in energy applications.

The test bed allows for the testing of both rolling element BBs and plain BBs. This enables the testing of various types of BB combinations and examining the influence that the ABB has on the rotor behavior and forces on the radial BBs. The design of the ABB for this test bed is shown in Fig. 3. The test bed BB includes the possibility to measure the following parameters:

- force on each of the bearing pads, as shown in Fig. 3
- displacement of the shaft at the bearing location
- temperature on each of the bearing pads, as shown in Fig. 3

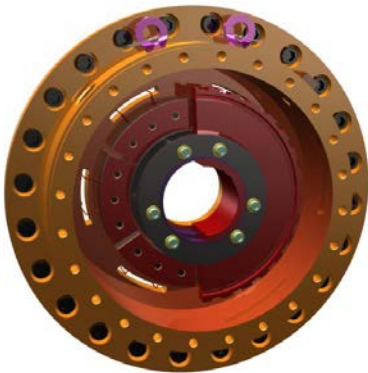

Figure 3. Illustration of the axial Backup bearing for the MFLP Test-Bed

The bearing is designed so that various materials can be used for the pads in order to manipulate the friction factor, thus enabling an investigation into effect that the friction factor has on the behavior of the rotor. Furthermore, various damping elements can also be used in order to test various configurations.

### B. Modelling principle for the MFLP axial backup bearing using BBSim

The concept of the BBSim model is the division into simpler sub-models of the complex interaction between the rotor, the AMBs, the BBs and the ABB. The main sub-models include a rotor-model, AMB-models and BB/stator-models in the translational direction and the rotational direction.

The model for the radial BBs, radial AMBs and rotor is described in previously published work [1, 13-15]. Similarly, to the previous published works on BBSim the axial backup bearing (ABB) model is divided into a linear and rotational model.

In order to determine the axial position of the rotor a simple mass-damper-spring system is used as shown in Fig. 4. The airgap size is a variable depending on the angular displacement of the shaft as shown in Fig. 5. As the angular displacement of the rotor increases the airgap size decreases.

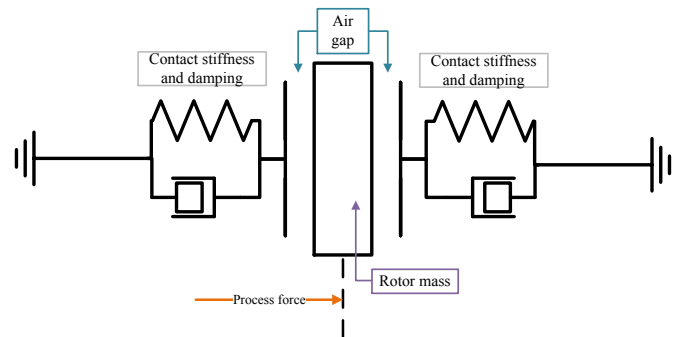

Figure 4. Schematic of a simple mass-damper-spring system for use with the ABB model

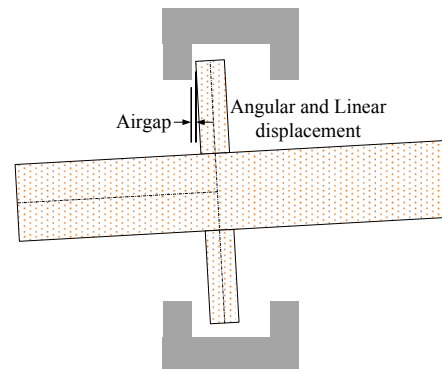

Figure 5. Schematic showing the layout of the ABB with angular and linear displacement of the rotor

The amount that the airgap in effect decreases is expressed by (1).

$$\Delta Z_{ag} = R_{ABB} \cdot (\sin \phi) \quad (1)$$

where  $\Delta Z_{ag}$  is the amount that the airgap is reduced by the angular deflection of the shaft,  $R_{ABB}$  is the radius where contact occurs in the ABB and  $\phi$  is the angular deflection of the shaft at the ABB location. Contact normal force and contact detection is based on (2).

$$F_{N_{ABB}} = \begin{cases} 0 & \text{if } Z_r < Z_{eff} \\ K_{ABB} \cdot (Z_r - Z_{eff}) + \\ C_{ABB} \cdot \frac{d(Z_r - Z_{eff})}{dt} & \text{if } Z_r \geq Z_{eff} \end{cases} \quad (2)$$

with  $Z_{eff} = (R_{ag} - \Delta Z_{ag})$

where  $F_{N_{ABB}}$  is the normal contact force,  $K_{ABB}$  and  $C_{ABB}$  is the ABB stiffness and damping in the axial direction,  $Z_r$  is the linear axial position of the rotor as determined by the model shown in Fig. 4,  $R_{ag}$  is the size of the nominal airgap of the ABB.

Because the rotor is rotating during contact there is friction forces present. The friction and normal forces present on the rotor can be transformed into force-moment pairs as shown in Fig. 6. The friction force is defined using normal Coulomb friction as given in (3) with  $\mu_{ABB}$  the dynamic friction factor between the contacting surfaces in the ABB.

$$F_{\mu_{ABB}} = F_{N_{ABB}} \cdot \mu_{ABB} \quad (3)$$

The magnitude of the breaking moment is dependent on the radius where contact occurs and the friction force caused by contact, as shown in (4). This breaking torque is then added to the breaking torque of the rotational rotor model as given in [1].

$$M_{break} = F_{\mu_{ABB}} \cdot R_{ABB} \quad (4)$$

The magnitude of the bending moment on the rotor is dependent on the normal force caused by contact and the radius where the contact occurs as shown in (5). The bending moment is added to the translational rotor model as discussed in [1].

$$M_{ABB} = F_{N_{ABB}} \cdot R_{ABB} \quad (5)$$

Using the described model together with the translational and rotational models in BBSim provides a complete solution for RDEs where the AMBs, the rotor, the ABB and the BBs are modelled.

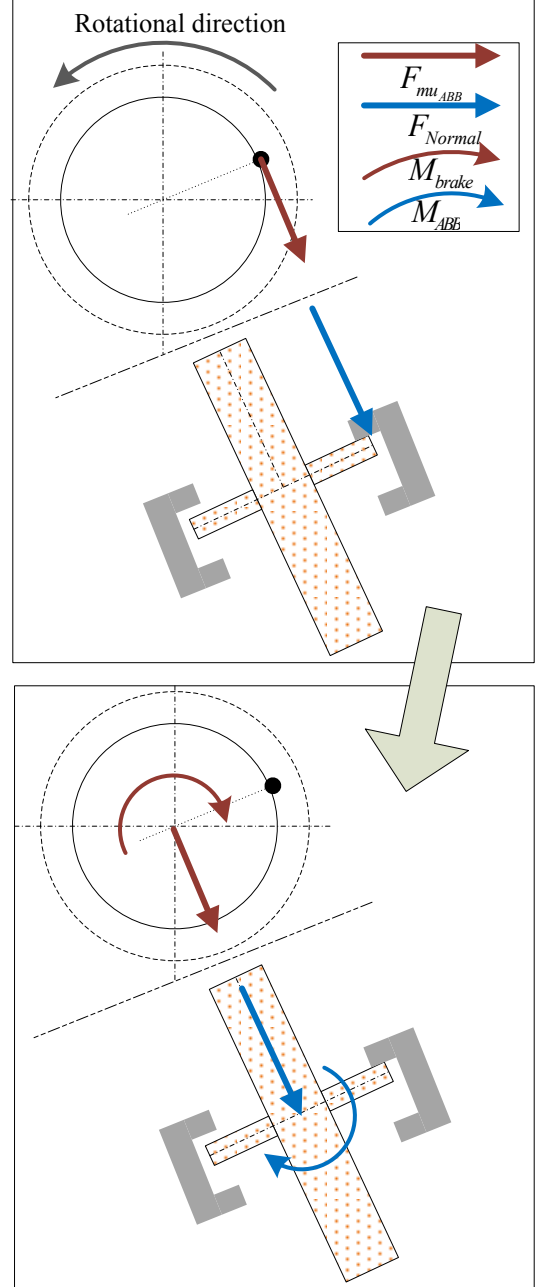

Figure 6. Schematic showing the force-moment pairs created by the normal and friction forces on the rotor

### III. RESULTS OBTAINED USING THE ABB MODEL IN BBSIM

For the purpose of this paper an investigation was done using BBSim and the proposed ABB model to determine the influence that the ABB has on the behavior of the rotor during a RDE. In order to determine the magnitude of the influence the RDEs need to be quantified.

#### A. Rotor delevitation quantification ( $V_{val}$ )

A way to measure the severity of a RDE is to use a nondimensionalised distance over time, to produce a nondimensionalised speed. The rationale behind the

nondimensionalised velocity can be found in the well-known formulas for impulse (6) and translational kinetic energy (7).

$$I \approx \overline{F} \cdot \Delta t = m \cdot \Delta v \quad (6)$$

$$E_k = \frac{1}{2} m \cdot v^2 \quad (7)$$

From the above equations, it is clear that the translational velocity is an important variable in both cases. The rationale is to obtain an indication of the amount of energy transformed into transverse motion. The transverse motion is an indication of the energy that the backup bearings dissipate or transform during a certain RDE and this is an indication of the degradation of the bearing-quality

The distance is non-dimensionalised by dividing with the airgap radius in order to produce a value that represents the number of times that the rotor travelled the entire distance of the airgap radius. The calculation of the non-dimensionalised distance is shown in (8), with  $n$  the window size (number of samples),  $i$  the index number,  $r_{airgap}$  the radius of the backup bearing clearance,  $x$  the position of the rotor center in the  $x$ -direction,  $y$  the position of the rotor center in the  $y$ -direction,  $k$  the index number for  $Dval$  and  $n_{total}$  the total number of samples in the RDE data [1,15].

$$Dval_k = \frac{\sum_{i=((k \cdot n)-n)+1}^{k \cdot n} \sqrt{(x_i - x_{i-1})^2 + (y_i - y_{i-1})^2}}{r_{airgap}} \quad (8)$$

with  $k = \left[ 1, \dots, \frac{n_{total}}{n} \right]$

This non-dimensionalised distance is divided by the time over which it was calculated to produce an average non-dimensionalised speed with the unit of per second. If the chosen window size is the same as the total number of samples in the RDE's data, there is only one  $Dval$  value. When the window size and total number of samples are the same (9) is used to determine the  $Vval$  value, with  $f_s$  the sampling frequency and  $n$  the window size [1].

$$Vval = Dval_1 \cdot \left( \frac{f_s}{n} \right) \quad (9)$$

It is important to note that the maximum value for  $Vval$  does not necessarily occur directly after the rotor delevitation. The dynamics of the system could cause a critical frequency being traversed at a lower rotational speed than the delevitation rotational speed. When a critical frequency of the system is traversed the behavior of the rotor in the backup bearings can become much more violent [1].

## B. Rotor model

The rotor model used to determine the results presented in this paper is shown in Fig. 7. The rotor weight is approximately 2.4 tons and the rotor has a length of approximately 3.8 m.

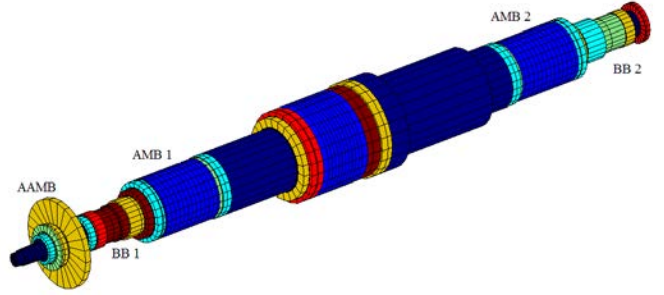

Figure 7. Rotor model used to produce results presented

The rotor is modelled in RotFE and consists of 118 nodes, with the locations for the AAMB, BB1, AMB1, AMB2 and BB2 as shown in Fig. 7.

## C. BBSim ABB results

The proposed model was used to determine the effect that two parameters has on the rotor behavior during a delevitation event these parameters are the radial distance where contact occurs within the ABB (shown in Fig. 8) and the axial force present on the rotor (shown in Fig. 9).

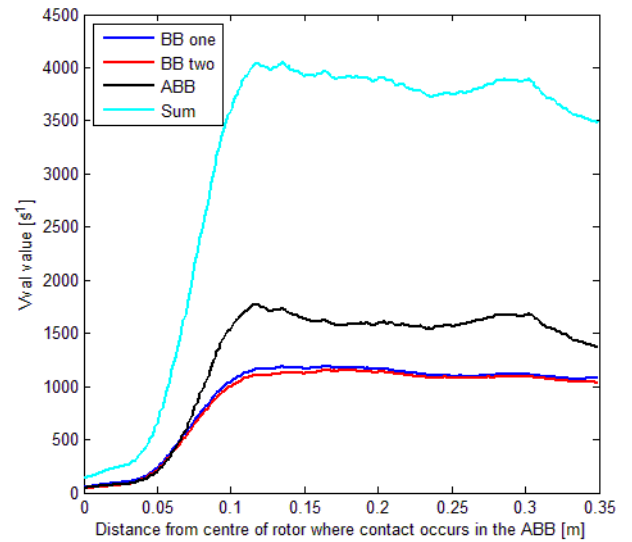

Figure 8. Results showing RDEs'  $Vval$  values for increasing radial distance where the ABB makes contact.

As can be seen in Fig. 8 the radial distance where contact occurs has a large influence on the rotor delevitation severity up until a radial distance of 0.12 it would seem that any further increase in the radial distance does not adversely affect the rotor behavior. It is important to note that as the distance increases the magnitude of  $F_{\mu_{abb}}$  and  $M_{break}$  also increases. The increase in the friction force would force the rotor to move radially and perpendicular to the contact location, this movement could possibly lead to forward



whirling or forward whip as stated in [3]. The increased breaking torque would cause the rotor to decelerate quicker thus causing the rotor to have a less violent behavior since the rotor speeds through any critical frequencies faster compared to a smaller breaking torque.

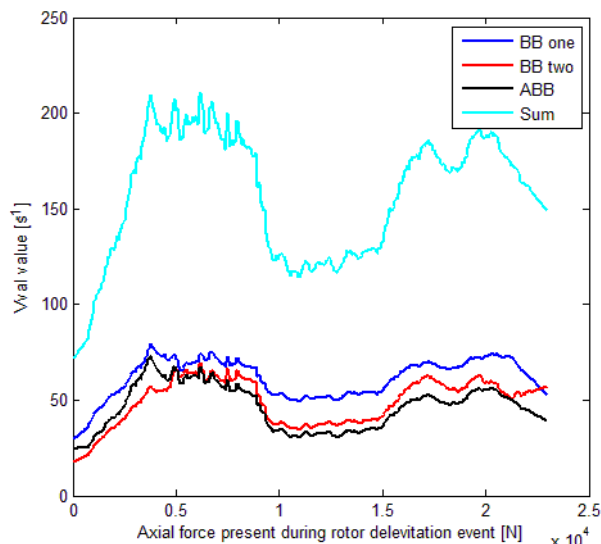

Figure 9. Results showing rotor delevitation behavior for increasing axial load.

As shown in Fig. 9 initially the axial force increases the  $V_{val}$  value up until 5 000 N where after the  $V_{val}$  value reaches a plateau until about 10 000 N where there is a sharp decrease in the  $V_{val}$  value, this pattern appears to be repeated with increments of 5 000 N, although the trend of the curves is slightly upward.

The upward trend of this curve would indicate that the rotor behavior is dependent on the axial force present; the fluctuations of the  $V_{val}$  values might be caused by axial critical frequencies cross-coupled with the radial critical frequencies of the system. The excitement of these frequencies is dependent on the magnitude of the axial force and the damping and stiffness present in both the radial and axial BB mounts.

#### CONCLUSION AND DISCUSSION

The model is able to calculate the influence that the forces present in the axial backup bearing has on the shaft motion during a RDE. The new test bed in Zittau will be used to generate results to validate the model, and to compare the severity of RDEs when using various sliding pad materials.

The BBSim model enables a total simulation solution when investigating AMB systems. The BBSim model includes the capability to simulate any number of AMBs and BBs (Sliding and rolling element) including the rotor dynamics of the rotor.

Although some conclusions can be made about the influence of the magnitude of the axial forces present and the radial distance where contact occurs, these conclusions require further investigation.

#### REFERENCES

- [1] J.J. Janse van Rensburg, "Delevitation modelling of an active magnetic bearing supported rotor," North West University, Potchefstroom, South Africa, PhD Thesis 2014.
- [2] J. Schmied and J. C. Pradetto, "Behaviour of a One Ton Rotor Being Dropped Into Auxiliary Bearings," , 1992.
- [3] J. Wilkes, J. Moore, D. Ransom, and G. Vannini, "An improved catcher bearing model and an explanation of the forward whirl/whip phenomenon observed in active magnetic bearing transient drop experiment," in *Proceedings of ASME Turbo Expo 2013: Turbine Technical Conference and Exposition*, San Antonio, TX, USA, 2013.
- [4] D. Ransom, A. Masala, J. Moore, G. Vannini, and Massimo Camatti, "Numerical and Experimental Simulation of a Vertical High Speed Motorcompressor Rotor Drop onto Catcher Bearings," in *11th International Symposium on Magnetic Bearings (ISMB11)*, Nara, Japan, 2008, pp. 136-143.
- [5] S.R. Penfield and E. Rodwell, "Auxiliary Bearing Design Considerations for Gas-Cooled Reactors," International Atomic Energy Agency, Palo Alto, USA, Report of a technical committee meeting (TCM) on Gas Turbine Power Conversion Systems for Modular HTGRs 2001.
- [6] M.T. Caprio, B.T. Murphy, and J.D. Herbst, "Spin Commissioning and Drop Tests of a 130 kW-Hr Composite Flywheel," , 2004.
- [7] E.E. Swanson, J.F. Walton, and H. Heshmat, "A 35,000 rpm Test Rig for Magnetic, Hybrid and Back-Up Bearings," *Transactions of the ASME*, vol. Paper No. 99-GT-180, pp. 1-7, 1999.
- [8] E.N. Cuesta, L.U. Medina, V.R. Rastelli, N.I. Montbrun, and S.E. Diaz, "A Simple Kinematic Model for the Behaviour of a Magnetically Levitated Rotor Operating in Overload Regime," , 2003.
- [9] G. Sun, A.B. Palazzolo, A. Provenza, and G. Montague, "Detailed Ball Bearing Model for Magnetic Suspension Auxiliary Service," *Journal of Sound & Vibration*, vol. 269, no. 3, pp. 933-963, 2004.
- [10] T. Rottenbach and F. Worlitz, "Long-term operation of an AMB-supported coolant pump in a lignite-fired power station - results and operational experience," in *11th International Symposium on Magnetic Bearings*, 2008.
- [11] M. Orth and R. Nordmann, "ANEAS, a Modelling Tool for Nonlinear Analysis of Active Magnetic Bearing Systems," in *Proceedings of the IFAC Conference of Mechatronic Systems*, Berkeley, CA, USA, 2002.
- [12] H. Neumann, C. Panescu, S. Düsterhaupt, and F. Worlitz, "MFLP - magnet- und Fanglagerprüfstand des Zittauer Kraftwerkslabores," in *9 Workshop Mechatronische Systeme*, 2013.
- [13] J.J. Janse van Rensburg, G. van Schoor, and P.A. van Vuuren, "Delevitation modelling of an active magnetic bearing supported rotor," in *Proceedings of the 12th International Symposium on Magnetic Bearings (ISMB12)*, Wuhan, China, 2010.
- [14] C. Vanek, F. Worlitz, J.J. Janse van Rensburg, and G. van Schoor, "Experimentelle und theoretische Untersuchungen zum Rotorabsturz in Wälzlager," in *Workshop Magnetlagertechnik Zittau-Chemnitz*, Zittau, 2011, pp. 97-101.
- [15] J.J. Janse van Rensburg, G. van Schoor, and P. van Vuuren, "The characterization of the severity of rotor delevitation events - A parametric study," in *Proceedings of the 13th International Symposium on Magnetic Bearings (ISMB13)*, Arlington, VA, USA, USA, 2012.