

A Model Based Digital PI Current Loop Control Design for AMB Actuator Coils

Lei Zhu^{1,a}, Larry Hawkins^{1,b}

¹Calnetix, Inc 23695 Via Del Rio Yorba Linda, CA 92782, USA

^alzhu@calnetix.com, ^blhawkins@calnetix.com

Abstract: This paper presents a digital PI current loop control design method for AMB actuator coils. The design takes into consideration the dynamics of each function block in the current loop. For the control of radial bearing actuator current, the digital redesign approach is used: an analog PI controller is designed first with root locus method and then discretized to obtain its digital counterpart. For the control of thrust bearing actuator current, eddy current effects are also considered as they cause frequency dependant inductance and resistance of the thrust coil. A swept sine test is conducted to measure the impedance of the thrust coil. Then a Matlab/Simulink model is built to carry out a frequency domain design of the digital PI controller with the measured impedance.

Keywords: AMB Actuator, Current Loop Control, Digital Redesign, Eddy Current

Introduction

Previous studies [1-3] have shown that PWM switching amplifiers are a suitable choice for AMB applications. Most off-the-shelf power amplifiers of this type [4] employ an on-board analog current control. A typical approach is a PI controller with a resistor and a capacitor to set the proportional and integral gain respectively. End users are recommended to change the components of default values to different ones, in order to achieve an optimal performance for their specific application. In most cases, this requires soldering work on PCBs, and if a trial-and-error approach is adopted to find the right values, it can evolve into a rather long process.

Compared to the inconvenience of implementing and modifying an analog control, a digital control which is typically implemented in a digital signal processor, is easy to update. This is one of the reasons that make digital control more appealing, especially when its design is based on an accurate model thus only minor fine tuning is needed later with the real hardware. And given the fast speed of today's digital signal processors, many of which have a multi-channel PWM signal generating function included, a great deal of features can be coded into the firmware with the digital approach, instead of adding a circuit for each of the features in the analog approach. Some of these features are: 1) switching logic - such as two and three state switching, 2) protection - such as over current protection, 3) diagnosis - such as actuator winding direction detection, and 4) monitoring - such as amplifier voltage saturation.

Hardware

A digital PI control design was developed and then tested with a six channel switching power amplifier board and a DSP controller board, as shown in Fig.1. The DSP board includes a Texas Instrument digital signal processor, which has 16 on-chip ADC channels and six pairs of complementary PWM outputs on-chip. Six of the ADC channels and all the PWM outputs are used in the control of the amplifier board. The DSP board is used for the magnetic bearing position control and monitoring as well as controlling the amplifier. The magnetic bearing control firmware that implements the position control and current control is programmed in C and stored in the DSP in on-chip flash memory.

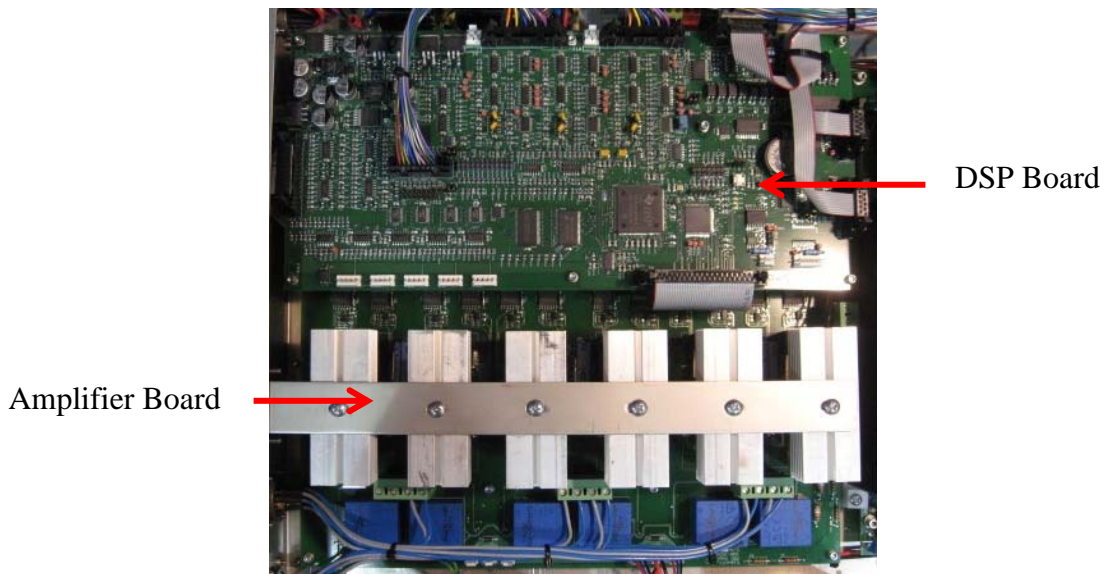

Fig.1: Amplifier Board and DSP Board Hardware

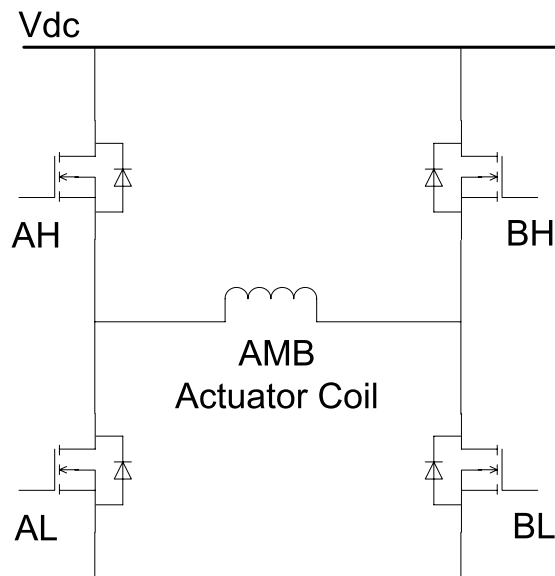

Fig.2: A Full H-Bridge Circuit

The amplifier board has the same three main function blocks for each of the six channels: a full H-bridge circuit with four MOSFETs, a gate drive circuit, and a current sensing circuit. The

amplifier uses full H-bridge circuits as shown in Fig 2 because the intended application is with Permanent Magnet (PM) bias magnetic bearings so bipolar current amplifiers are needed. Magnetic bearings are typically used in a five axis system, with four radial axes and one thrust axis so only five current amplifiers are usually required. However, it is very common for the thrust bearing to require more power than the radial bearings, so a sixth channel was included for paralleling in some applications.

Fig. 3 shows the function block diagram of the current control loop. During the normal operation of a magnetic bearing system, a current command (current CMD in Fig. 3) generated by the position control is sent to the current control loop and is compared with the sampled current feedback signal. The difference between the command and the feedback, called current error, is then passed to a digital PI controller to calculate a new current command signal. This signal is then sent to the PWM generator in the DSP to produce new H-bridge gate switching signals. The gate signals are sent to the amplifier board through a ribbon cable to control the MOSFETs, thus controlling the duration of the PWM voltage applied to the actuator coil to generate the desired current. A current sensor on the amplifier board measures the actual current going from the H-bridge to the AMB actuator coil. The sensor signal is fed back to the DSP controller board through a second ribbon cable. On the DSP board, the signal goes through an anti-alias filter and is sample by the on-chip ADC. The discretized sensor signal is again compared with the command signal for further updates on coil current.

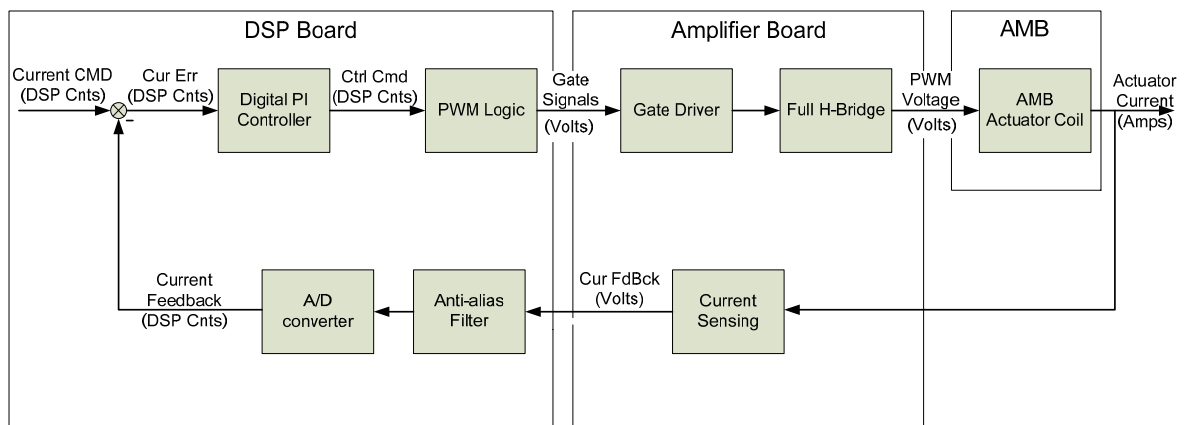

Fig.3: Function Block Diagram of Current Control Loop

Modeling and Control Design

For the current control of a radial bearing actuator coil, the *Digital Redesign* approach [5] is used. An analog controller is designed in continuous time frequency domain first and is then discretized to obtain its digital counterpart. The one step forward method is adopted for the discretization in this application. To design the analog PI controller, the dynamics of each of the function blocks in the loop, as shown in Fig. 3, is taken into consideration: the actuator coil is represented as $1/(Ls + R)$, with L, the coil inductance, being an analytical value generated by finite element analysis of the radial actuator, and R, the coil resistance, being a measured value including the cable resistance; the switching logic and the H-bridge can be treated as a gain stage, named K_g in this design; a delay of one sample period due to logic

implementation is considered in the loop and is approximated by a second order Pade approximation; the current sensor, based on the manufacturer's datasheet, is represented by a first order low pass filter with a corner frequency of 50kHz; and the anti-alias filter is a second order low pass filter with un-damped natural frequency of 5kHz and 0.52 damping ratio.

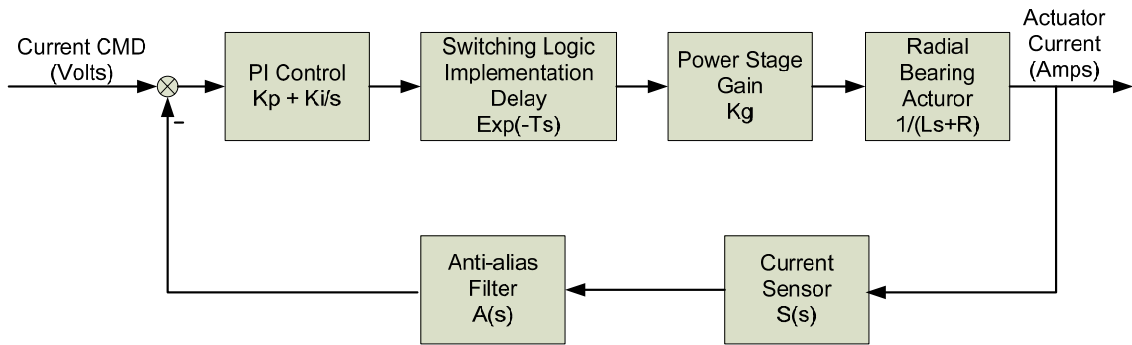

Fig. 4: Current Control Loop of a Radial Bearing Actuator Coil – Analog Design

Root locus approach is used to design the analog PI control: a range of the proportional and integral gains are selected by the designer based on previous experience with off-the-shelf analog power amplifiers; then the gains are changed in the given range and the optimal values of the gains are selected so that the dominant pair of complex poles give a good bandwidth and damping of the closed loop.

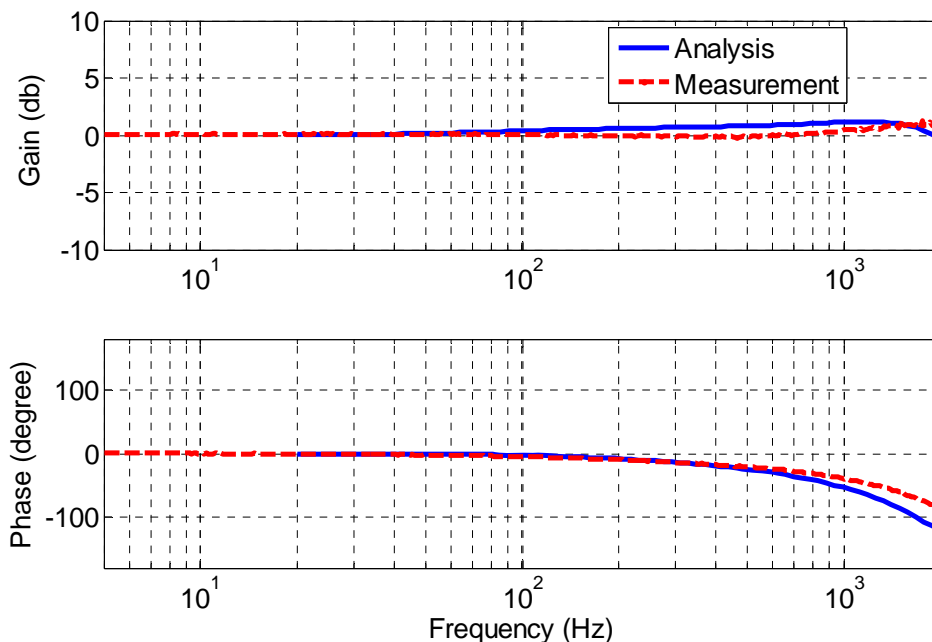

Fig. 5: Closed Loop Transfer Function of Radial Bearing Current Control

Fig. 5 shows a comparison between the predicted (analysis) and measured closed loop transfer function of a radial bearing current control loop with the designed digital PI controller. In the frequency range between 0Hz and 2kHz, the maximum difference in magnitude is 1.2dB, or 15% difference between analysis and measurement. Regarding phase, the match between analysis and measurement is within 10 degrees between 0 to 1kHz. However, between 1kHz

and 2kHz, the phase difference increases noticeably. Two possible reasons for this phase difference are: 1) the dc inductance (from FEA) of the radial bearing actuator used in the analysis is different from the real value, or 2) eddy current effects are starting to impact the impedance of the radial actuator between 1kHz and 2kHz. Due to time constraint, the exact reason causing the phase difference is left for future development.

For the current control of a thrust bearing actuator coil, all the components shown in Fig. 3 are considered here also. The key difference, which results a design approach change, is that for a thrust bearing in the frequency range we are interested in, the inductance and the resistance of the coil change as frequency changes due to a strong eddy current effect in the thrust bearing. FEA analysis can provide an estimation of the inductance and resistance of the coil at different frequencies. However, when we designed the current control for the thrust bearing, the bearing hardware was available, thus an impedance measurement was conducted.

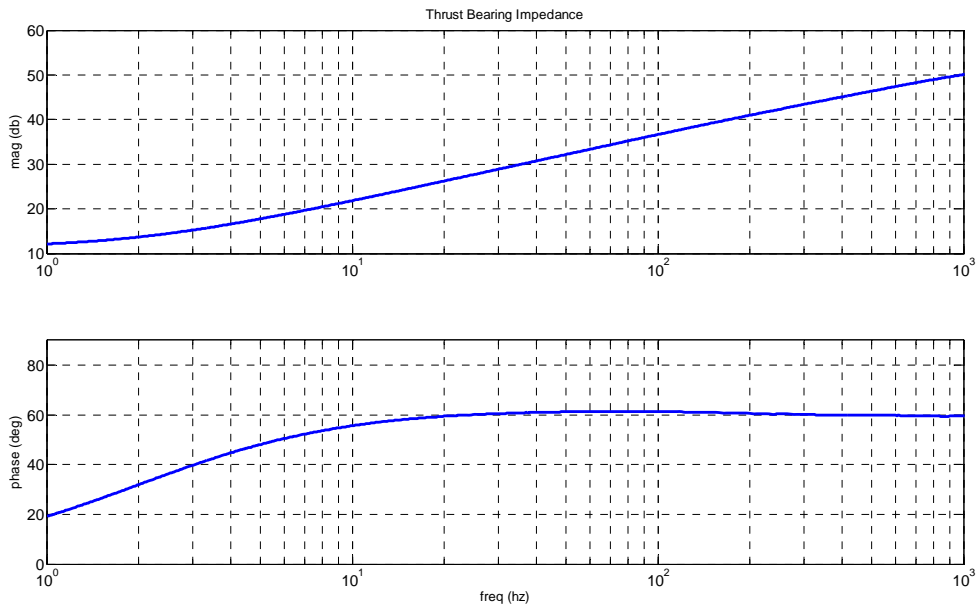

Fig. 6: The Measured Impedance of the Thrust Bearing Actuator Coil

The measured impedance as shown in Fig.6 presents an interesting phenomenon of the thrust bearing, which is worth noting. The magnitude plot has a 15dB/decade slope at high frequencies, and the phase plot converges to 60degree. This is different from an inductor with an air core or with a laminated core, which has a 20dB/decade slope for magnitude and a 90degree phase at high frequencies. As [6-7] points out, these unique impedance plots indicate that the thrust bearing actuator is a fractional order system. Based on the impedance trend at high frequency, a possible fit, which should be electromagnetically meaningful, of the measured impedance is in the form of

$$R + \frac{Ls}{1 + e \times \sqrt[3]{s}} \quad (1)$$

with R being the dc resistance of the coil, the L being the dc inductance of the coil, e is an eddy current effect coefficient, which can be estimated from curve-fitting the measured

impedance or derived from a rigorous analysis as shown in [6-7]. It is also possible to fit the measured impedance with a high order integer order system. However, this type of fitting only guarantees a decent match in the frequency range where measured data exist. It can not capture the physical meaning of eddy current effect: the inductance decreases and resistance increases as frequency increases. And this type of fitting will not be suitable if any time domain analysis is involved.

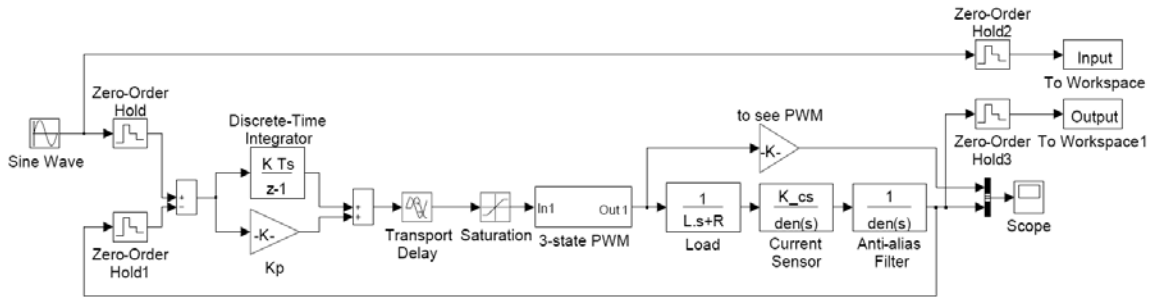

Fig. 7: Matlab/Simulink Model for Thrust Bearing Current Control Design

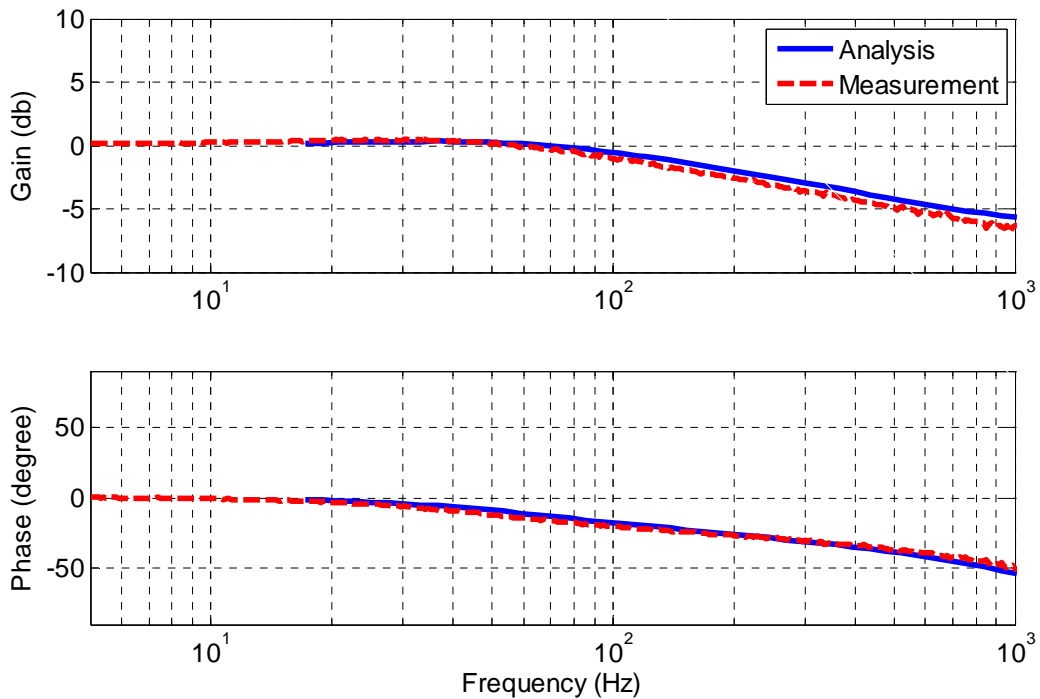

Fig. 8: Closed Loop Transfer Function of Thrust Bearing Current Control

Since the inductance and the resistance of the thrust bearing actuator is frequency dependant, and there is no existing function in Matlab to analyze such a system, a Simulink model, as shown in Fig. 7, is built for doing the analysis. Basically, control parameters are selected to achieve a closed current loop with a high bandwidth and with low phase lag in the desired frequency range for the thrust bearing. To evaluate the performance of the parameters, a swept sine simulation is conducted with the model. At each frequency during the simulation, the inductance and resistance calculated from the measured impedance are applied to the model; a fixed number of sine wave cycles are applied to the input in the model. At the output in the

model, a sine wave with the same frequency but with different gain and phase presents. One can capture the output waveform and run FFT to get the gain and phase information of the output at each frequency. This will provide us the closed loop transfer function of the current loop, which one can then use to judge whether the control provides a good bandwidth and a good phase profile.

Fig. 8 shows a comparison between the predicted and measured closed loop transfer function of a thrust bearing current control loop with the designed digital PI controller. In the frequency range between 0Hz and 1kHz, the difference on magnitude between measurement and analysis is within 1dB, or a 12% maximum magnitude difference; the phase difference between measurement and analysis is within 5 degrees.

Summary

This paper presents a digital PI current loop control design approach for both radial and thrust magnetic bearing actuators. The dynamics of all the function blocks in the current loop are included in the design. The digital redesign approach is used for a radial bearing actuator, and a Matlab/Simulink model that takes into consideration of the eddy current effects of the thrust bearing is built for control design for thrust bearing actuator. The initial results measured on the bearing hardware demonstrate the effectiveness of the design approach.

References

- [1] U. Schroder, "Power Amplifiers for Magnetic Bearings", *Proceeding of Magnetic Bearings, Magnetic Drives and Dry Gas Seals Conference and Exhibition*, 1995, Alexandria, Virginia.
- [2] Jing Zhang, Jens Oliver Schulze and Natale Barletta, Synchronous three-level PWM power amplifier for active magnetic bearings, *Proceeding of 5th International Symposium on Magnetic Bearings*, 1996, Kanazawa, Japan
- [3] F. J. Keith, E. H. Maslen, R. R. Humphris, and R. D. Williams, Switching Amplifier Design for Magnetic Bearings, *Proceedings of 2nd International Symposium on Magnetic Bearings*, 1990, Tokyo, Japan
- [4] Advanced Motion Controls, PWM Servo Amplifiers, 1999-2000 Catalog and Technical Manual.
- [5] Frank Lewis, *Applied Optimal Control and Estimation; Digital Design and Implementation*, Prentice-Hall, 1992
- [6] Lei Zhu, Carl Knospe, and Eric Maslen, "An Analytical Model of a Non-laminated Cylindrical Magnetic Actuator including Eddy Currents", *IEEE Transaction on Magnetics*, Vol. 41, No. 4, 1248-1258, 2005
- [7] Lei Zhu and Carl Knospe, "Modeling of Non-laminated Electromagnetic Suspension Systems", *IEEE Trans. Mechatronics*, vol. 15, No. 1, pp. 59- 69, Feb. 2010